

**uponor**

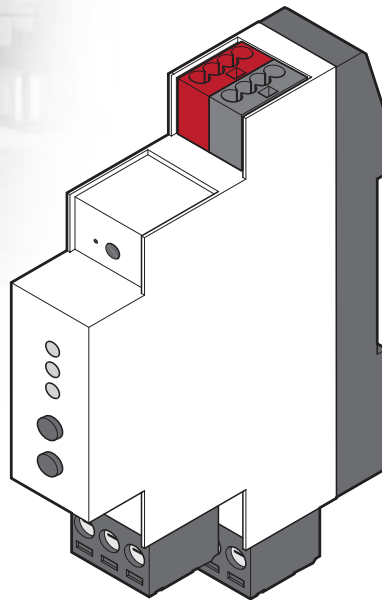

# **Uponor Smatrix Base PRO R-147 KNX**

EN INSTALLATION AND OPERATION  
MANUAL

# Table of contents

<b>1</b>	<b>Copyright and disclaimer .....</b>	<b>3</b>
<b>2</b>	<b>Preface .....</b>	<b>4</b>
2.1	Safety instructions .....	4
2.2	Correct disposal of this product (Waste Electrical and Electronic Equipment) .....	4
<b>3</b>	<b>Description .....</b>	<b>5</b>
3.1	System overview .....	5
3.2	Required devices and softwares .....	5
3.3	Installation procedure .....	5
<b>4</b>	<b>Install KNX gateway module .....</b>	<b>6</b>
4.1	Prepare for installation .....	6
4.2	Install Uponor Smatrix Base PRO system .....	6
4.3	Attach KNX gateway module to the wall using DIN rail .....	6
4.4	Installation example .....	7
4.5	Disconnect the Smatrix Base PRO system from AC power .....	8
4.6	Disconnect the KNX bus from DC power .....	8
4.7	Connect the KNX gateway module to the Smatrix Base PRO bus .....	9
4.8	Connect the KNX gateway module to the KNX bus .....	10
4.9	Connect the KNX bus to DC power .....	10
4.10	Connect the Smatrix Base PRO system to AC power .....	11
4.11	Enable the KNX gateway module in the interface I-147 .....	11
<b>5</b>	<b>System setup .....</b>	<b>12</b>
5.1	Prepare for system setup .....	12
5.2	ETS® product data file .....	12
5.3	Assign ETS® address to KNX gateway module .....	12
5.4	Setting up a system .....	13
<b>6</b>	<b>Data point lists .....</b>	<b>16</b>
<b>7</b>	<b>Troubleshooting .....</b>	<b>18</b>
7.1	KNX gateway module LEDs .....	18
7.2	KNX gateway module error codes .....	19
7.3	Resetting the KNX gateway module .....	19
7.4	LED error codes .....	20
<b>8</b>	<b>Technical data .....</b>	<b>23</b>
8.1	Technical data .....	23
8.3	Dimensions .....	24

# 1 Copyright and disclaimer

Uponor has prepared this installation and operation manual and all the content included solely for information purposes. The contents of the manual (including graphics, logos, icons, text, and images) are copyrighted and protected by worldwide copyright laws and treaty provisions. You agree to comply with all copyright laws worldwide in your use of the manual. Modification or use of any of the contents of the manual for any other purpose is a violation of Uponor's copyright, trademark and other proprietary rights.

The presumption for the manual is that the safety measures have been fully complied with and, further, that Uponor Smatrix Base, including any components that are part of such system, covered by the manual:

- is selected, planned and installed and put into operation by a licensed and competent planner and installer in compliance with current (at the time of installation) installation instructions provided by Uponor as well as in compliance with all applicable building and plumbing codes and other requirements and guidelines;
- has not been (temporarily or continuously) exposed to temperatures, pressure and/or voltages that exceed the limits printed on the products or stated in any instructions supplied by Uponor;
- remain in its originally installed location and is not repaired, replaced or interfered with, without prior written consent of Uponor;
- is connected to potable water supplies or compatible plumbing, heating and/or cooling products approved or specified by Uponor;
- is not connected to or used with non-Uponor products, parts or components except for those approved or specified by Uponor; and
- does not show evidence of tampering, mishandling, insufficient maintenance, improper storage, neglect or accidental damage before installation and being put into operation.

While Uponor has made efforts to ensure that the manual is accurate, Uponor does not guarantee or warrant the accuracy of the information contained herein. Uponor reserves the right to modify the specifications and features described herein, or discontinue manufacture of Uponor Smatrix Base PRO Gateway Module R-147 KNX described at any time without prior notice or obligation. The manual is provided "as is" without warranties of any kind, either expressed or implied. The information should be independently verified before using it in any manner.

**To the fullest extent permissible, Uponor disclaims all warranties, expressed or implied, including, but not limited to, the implied warranties of merchantability, fitness for particular purpose and non-infringement.**

This disclaimer applies to, but is not limited to, the accuracy, reliability or correctness of the manual.

**Under no circumstances shall Uponor be liable for any indirect, special, incidental or consequential damages or loss that result from the use of or the inability to use the materials or information in the manual, or any claim attributable to errors, omission or other inaccuracies in the manual, even if Uponor has been advised of the possibility of such damages.**

**This disclaimer and any provisions in the manual do not limit any statutory rights of consumers.**

## 2 Preface

This installation and operation manual describes how to install and operate the Uponor Smatrix Base PRO Gateway Module R-147 KNX.

### 2.1 Safety instructions

#### Warnings used in this manual

The following symbols are used in the manual to indicate special precautions when installing and operating any Uponor equipment:



#### **WARNING!**

Risk of injury. Ignoring warnings can cause injury or damage components.



#### **CAUTION!**

Ignoring cautions can cause malfunctions.

#### Safety measures

Conform to the following measures when installing and operating any Uponor equipment:

- Read and follow the instructions in the installation and operation manual.
- Installation must be performed by a competent person in accordance with local regulations.
- It is prohibited to make changes or modifications not specified in this manual.
- All power supplies must be switched off before starting any wiring work.
- Do not use water to clean Uponor components.
- Do not expose the Uponor components to flammable vapours or gases.

Uponor cannot accept any responsibility for damage or breakdown that can result from ignoring these instructions.

#### Power



#### **WARNING!**

The Uponor system uses 50 Hz, 230 V AC power. In case of emergency, immediately disconnect the power.

#### Technical constraints



#### **CAUTION!**

To avoid interference, keep installation/data cables away from power cables of more than 50 V.

### 2.2 Correct disposal of this product (Waste Electrical and Electronic Equipment)



#### **NOTE!**

Applicable in the European Union and other European countries with separate collection systems



This marking shown on the product or its literature indicates that it should not be disposed with other household waste at the end of its working life. To prevent possible harm to the environment or human health from uncontrolled waste disposal, please separate this from other types of wastes and recycle it responsibly to promote the sustainable reuse of material resources.

Household users should contact either the retailer where they purchased this product, or their local government office, for details of where and how they can take this item for environmentally safe recycling.

Business users should contact their supplier and check the terms and conditions of the purchase contract. This product should not be mixed with other commercial wastes of disposal.

## 3 Description

### 3.1 System overview

An Uponor Smatrix Base PRO system can be connected to a standard KNX bus via an Uponor Smatrix Base PRO Gateway Module R-147 KNX (KNX gateway module). The KNX gateway module will act as a bridge between the wired Uponor Smatrix Base PRO system bus and the wired KNX bus.

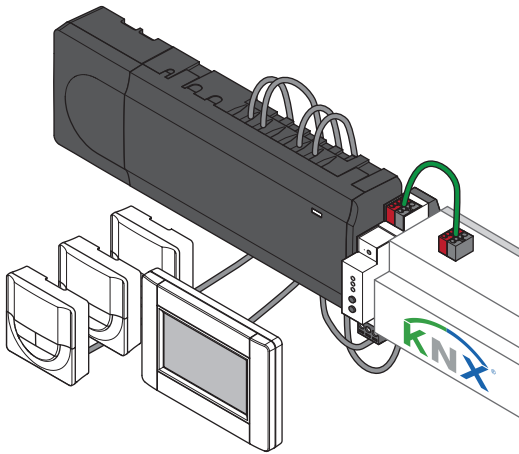

The KNX gateway module offers several possibilities to operate and monitor an Uponor Smatrix Base PRO system in a KNX environment, such as:

- Access to setpoints for every room.
- Access to readout of room temperatures.
- Access to alarm monitoring.
- Access to heat curve offset in Uponor Smatrix Move PRO controller (if connected to a Base PRO system bus).
- Usage of either Uponor or KNX thermostats in the system.
- Usage of standard KNX system modes for Comfort/ECO and heating/cooling.

### 3.2 Required devices and softwares

The following list states what is needed to utilize a full KNX connection for a Uponor Smatrix Base PRO system:

- Uponor Smatrix Base PRO Gateway Module R-147 KNX.
- Up to 16 Uponor Smatrix Base PRO controllers (Base PRO controller) and an Uponor Smatrix Base PRO Interface I-147 (interface I-147).
- KNX PSU and PC interface.
- Data point lists for the Base PRO controllers (found in this manual).
- ETS® tool (version 5 or higher, software provided by the KNX organisation) installed on a computer connected to the KNX bus.
- ETS® product data file for Uponor Smatrix Base PRO.

### 3.3 Installation procedure

Uponor recommends following the process described below to guarantee the best possible installation results.



#### NOTE!

Installation of the KNX gateway module requires basic knowledge and training on the ETS® tool and KNX systems.

Stage	Procedure	Page
1	Prepare for installation	—
2	Install Uponor Smatrix Base/Base PRO system*	—
3	Power off the Smatrix Base PRO system	—
4	Power off the KNX system	—
5	Connect the KNX gateway module to the Smatrix Base PRO bus	—
6	Connect the KNX gateway module to the KNX bus	—
7	Power up the Smatrix Base PRO system	—
8	Enable the KNX gateway module in the interface I-147	—
9	Power up the KNX system	—
10	System setup	—

\* See the installation and operation for Uponor Smatrix Base/Base PRO for more information.

## 4 Install KNX gateway module

### 4.1 Prepare for installation

Before starting the installation:

- Study the wiring diagram in the end of this manual or in the quick guide.
- Study the installation examples in manual.

*See section 4.X Installation example for more information.*

- Ensure that the Smatrix Base PRO system is setup correctly and powered off.

*See the installation and operation manual for Uponor Smatrix Base/Base PRO for more information.*

- Ensure that the KNX system is installed (not yet setup in ETS) correctly and powered off.

*See separate documentation (not supplied by Uponor) for more information.*

To determine where to best place the Uponor Smatrix Base components, follow these guidelines:

- Ensure that the KNX gateway module can be installed close to the Smatrix Base PRO bus.
- Ensure that the KNX gateway module can be installed close to the KNX bus.
- Ensure that there is room for the KNX gateway module on a DIN rail.
- Ensure that the KNX gateway module is protected from running or dripping water.
- Check that connectors and switches are easily accessible.

### 4.2 Install Uponor Smatrix Base PRO system

Ensure that the Smatrix Base PRO system is setup correctly before continuing with this installation procedure.

*See the installation and operation manual for Uponor Smatrix Base/Base PRO for more information.*

### 4.3 Attach KNX gateway module to the wall using DIN rail

Attach the KNX gateway module to a DIN rail in a cabinet (recommended), or to a DIN rail attached to a wall using screws and wall plugs.

The figure below shows how to attach the KNX gateway module using a DIN rail.

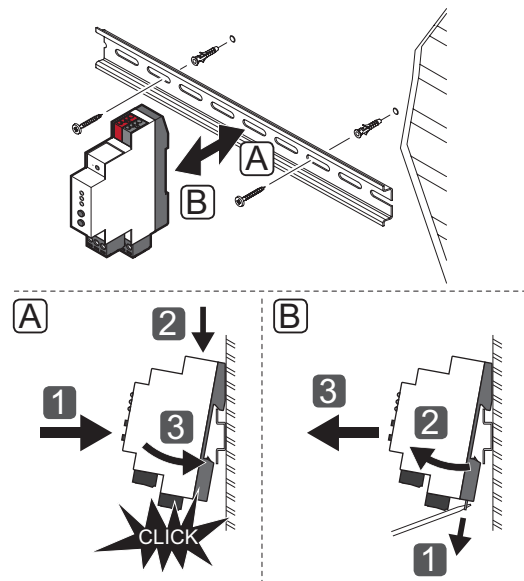

## 4.4 Installation example

A

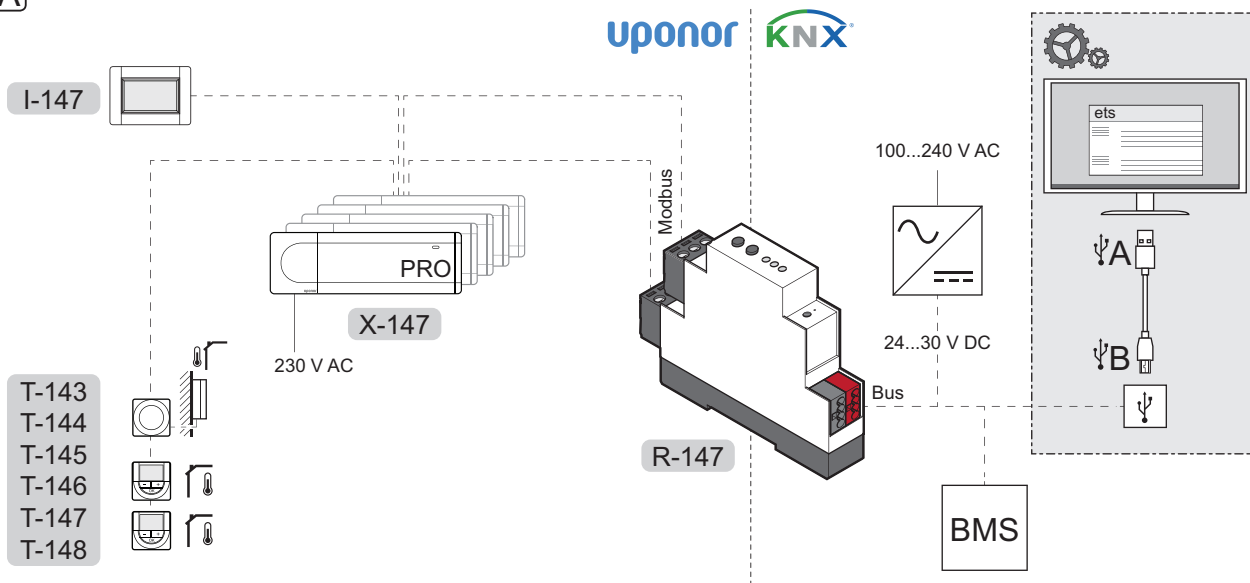

B

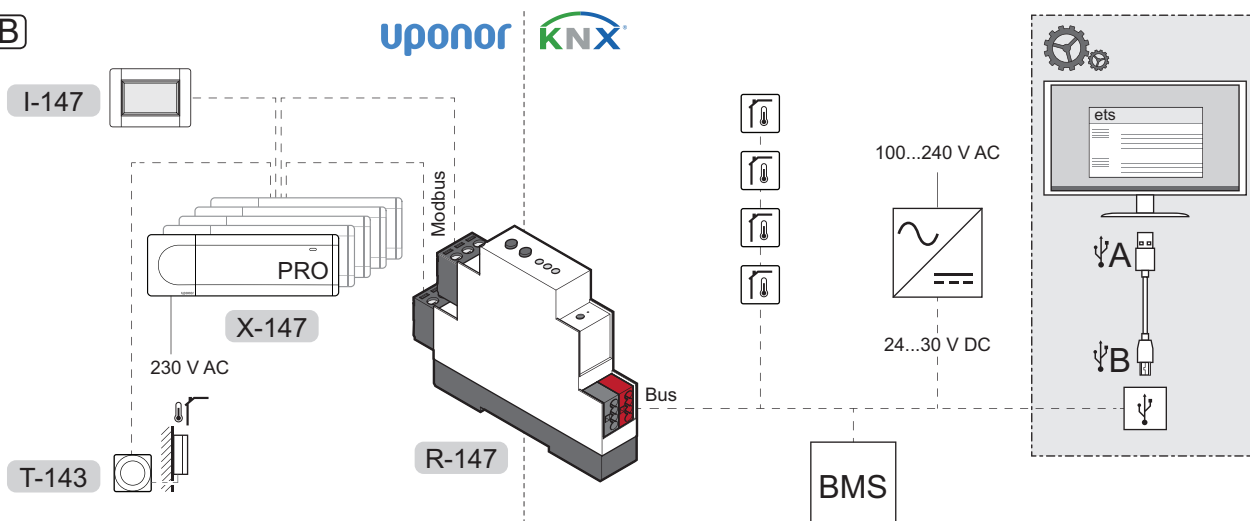

### CAUTION!

An Uponor Smatrix Wave PLUS Interface I-147 is needed to enable the KNX Gateway module.



### CAUTION!

A separate power supply is needed for the KNX bus.



### NOTE!

The KNX gateway module only sends Smatrix Base PRO data point values to the KNX bus when the data point has changed.

See also the wiring diagram in the end of the manual.

### A. SYSTEM WITH UPONOR THERMOSTATS

A connection example of an Uponor Base PRO system connected to the KNX bus using the KNX gateway module.

- The system is setup to use Uponor room thermostats.
- An outdoor sensor is connected to a public thermostat T-143 registered to the Smatrix Base PRO system as a system device.
- A building management system (BMS) is connected to the KNX bus.
- The ETS® configuration tool is used to setup the KNX system.

### B. SYSTEM WITH KNX THERMOSTATS

A connection example of an Uponor Base PRO system connected to the KNX bus using the KNX gateway module.

- The system is setup to use KNX room thermostats.
- An outdoor sensor is connected to a public thermostat T-143 registered to the Smatrix Base PRO system as a system device.
- A building management system (BMS) is connected to the KNX bus.
- The ETS® configuration tool is used to setup the KNX system.

## 4.5 Disconnect the Smatrix Base PRO system from AC power



### WARNING!

Electrical installation and service behind secured 230 V AC covers must be carried out under the supervision of a qualified electrician.

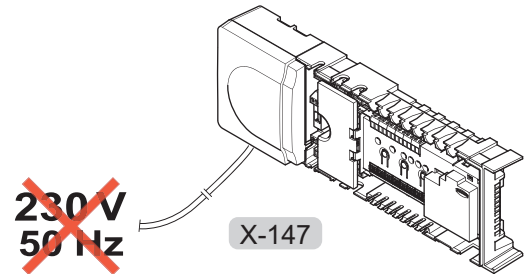

Disconnect the Smatrix Base PRO system from AC power before continuing with the installation.

## 4.6 Disconnect the KNX bus from DC power



### WARNING!

There is 24 – 30 V DC in the KNX bus, if connected to the mains.

Disconnect the KNX bus from DC power before continuing with the installation.





## 4.7 Connect the KNX gateway module to the Smatrix Base PRO bus

The illustration shows the KNX gateway module connected to the Smatrix Base PRO controller.

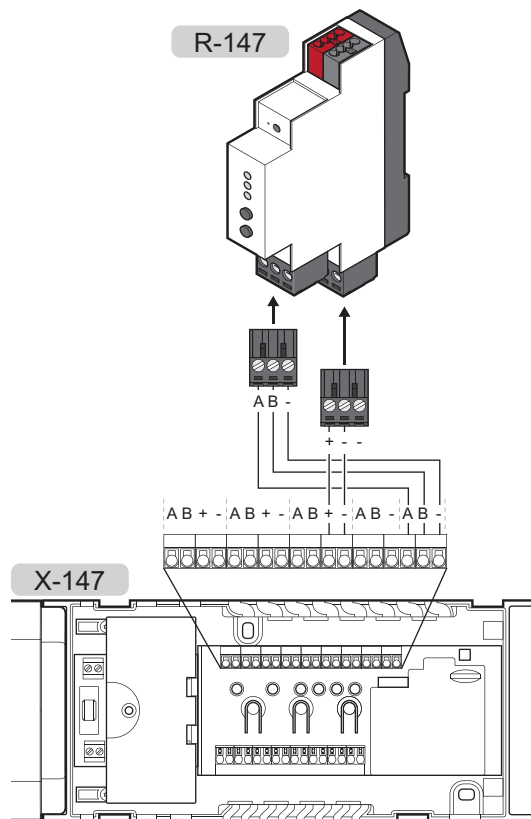

### NOTE!

The connection terminals on Smatrix Base PRO controller and the KNX gateway module are detachable to facilitate easy installation.

To connect the KNX gateway module to the Smatrix Base PRO controller:

1. Study the wiring diagram to locate the connection terminal positions.
2. Ensure that the power is disconnected from the controller.
3. Remove the cover from the Smatrix Base PRO controller.  
*See the installation and operation manual for Uponor Smatrix Base/Base PRO for more information.*
4. Connect the wires from the thermostat bus on the Smatrix Base PRO controller to the lower connector on the KNX gateway module.
  - + terminal on the controller to + terminal on the KNX gateway module.
  - - terminal on the controller to - terminal on the KNX gateway module.
5. Connect the wires from the system bus on the Smatrix Base PRO controller to the upper connector on the KNX gateway module.
  - **A** connector on the controller to **A** connector on the KNX gateway module.
  - **B** connector on the controller to **B** connector on the KNX gateway module.
  - - connector on the controller to - connector on the KNX gateway module.
6. Tighten the screws fixing the wires to the connectors.

#### 4.8 Connect the KNX gateway module to the KNX bus

The illustration shows the KNX gateway module connected to the KNX bus.

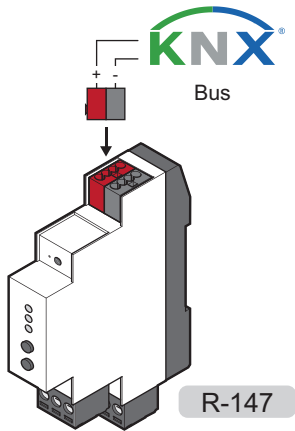

#### WARNING!

There is 24 – 30 V DC in the KNX bus, if connected to the mains.



#### NOTE!

The connection terminal KNX gateway module is detachable to facilitate easy installation.

To connect the KNX gateway module to the Smatrix Base PRO controller:

1. Study the wiring diagram to locate the connection terminal positions.
2. Ensure that the power is disconnected from the KNX bus.
3. Connect the wires from the KNX bus to the KNX connector on the KNX gateway module.
  - + terminal on the controller to + terminal (red) on the KNX gateway module.
  - - terminal on the controller to - terminal (grey) on the KNX gateway module.

#### 4.9 Connect the KNX bus to DC power



#### WARNING!

There is 24 – 30 V DC in the KNX bus, if connected to the mains.

1. Check that all wiring is complete and correct:
  - Smatrix Base PRO bus
  - KNX bus
2. Connect power to the KNX bus.

#### 4.10 Connect the Smatrix Base PRO system to AC power

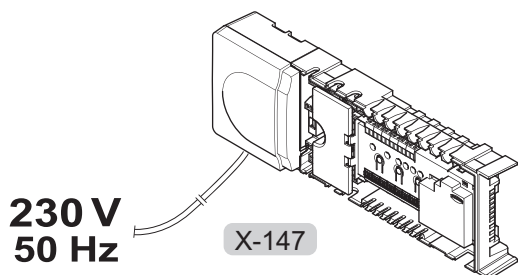

1. Check that all wiring is complete and correct:
  - Smatrix Base PRO bus
  - KNX bus
  - Power to the KNX bus
2. Connect power to the Smatrix Base PRO Controller.
3. The main 3 LEDs (PWR, KNX, and BUS) on the KNX gateway module powers on and turns red. The PWR LED (power) changes from red to green after a couple of seconds.

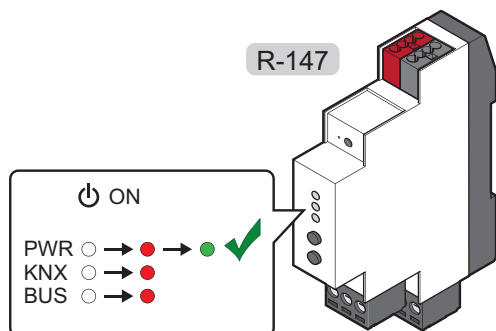

#### NOTE!

A flashing LED indicates that the KNX gateway module receives data via Modbus and/or KNX.

#### 4.11 Enable the KNX gateway module in the interface I-147

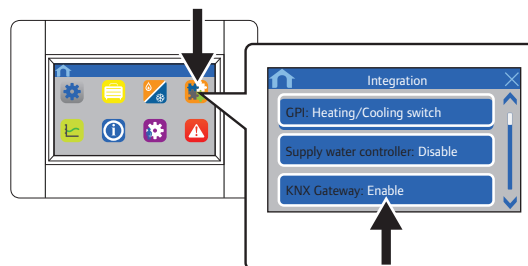

To connect the enable the KNX gateway module in interface I-147:

1. Go to the **Integration** menu (**Main menu > Integration**).
2. Press **KNX Gateway: Disable**.
3. Press **Enable** to activate communication between the interface and the KNX gateway module.

The Modbus LED on the KNX gateway module changes from red to green.

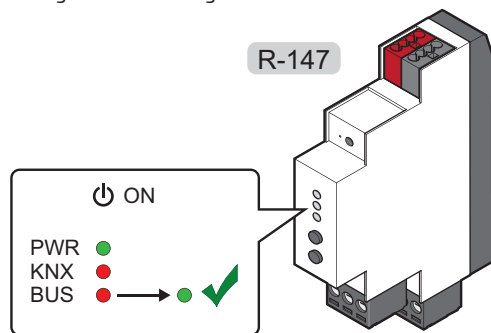

#### NOTE!

When enabling the KNX gateway module, in the interface I-147, all ECO setback values and Cooling offset will be set to 0 °C throughout the Smatrix Base PRO system.

## 5 System setup

### 5.1 Prepare for system setup



#### NOTE!

Installation of the KNX gateway module requires basic knowledge and training on the ETS® tool and KNX systems.

Before starting the system setup:

- Ensure that the KNX gateway module is installed correctly.  
*See section 4 Install KNX gateway module for more information.*
- Ensure that the Smatrix Base PRO system is setup correctly and powered on.  
*See the installation and operation manual for Uponor Smatrix Base/Base PRO for more information.*
- Ensure that the KNX system is installed (not yet setup in ETS) correctly and powered on.  
*See separate documentation (not supplied by Uponor) for more information.*
- Ensure that the PWR (power) and BUS (Modbus) LED on the KNX gateway module are green.
- Note where all Uponor Smatrix Base PRO devices are placed and how they are connected to each other.
- Download and install the ETS® tool (version 5 or higher, software provided by the KNX organisation) on a computer connected to the KNX bus.
- Download the ETS® product data file for Uponor Smatrix Base PRO Gateway Module R-147 KNX from the Uponor website.  
*See section 5.2 ETS® product data file for more information.*
- Locate the data point lists for the Base PRO controllers (found in this manual).

### 5.2 ETS® product data file

To configure the KNX gateway module and other connected Smatrix Base PRO devices a product data file containing these devices is needed.

1. Download the product data file from the Uponor website (<http://www.uponor.com/smatrix/knx>).
2. Load the product data file into the ETS® tool.

### 5.3 Assign ETS® address to KNX gateway module

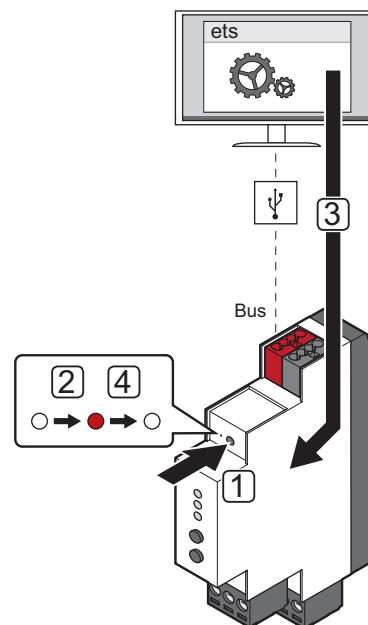

#### CAUTION!

Do not disconnect the KNX gateway module from the power source when the KNX LED is flashing red (receiving data). It may cause configuration issues with the controllers on the Modbus side.



#### NOTE!

Ensure that no other KNX device is in programming mode when completing these steps.

To assign ETS® address to the KNX gateway module:

1. Press the programming button, using a pointed object, on the KNX gateway module to set into programming mode.
2. The programming LED is turned on (red).
3. Start the ETS® tool, add the KNX gateway module to the Topology, and assign a unique ETS® address to the KNX gateway module.
4. If the ETS® address is assigned successfully, the programming LED is turned off.

## 5.4 Setting up a system

### ETS® TOOL

In order for the Uponor Smatrix Base PRO system to communicate with the KNX bus, the KNX gateway module must be programmed in the ETS® tool.

The ETS® tool is a software provided by the KNX organisation which must be installed and run on a computer connected to the KNX bus.

### ETS® CONFIGURATION FLAGS

There is usually no need to change the configuration flags from default settings when programming the system with the ETS® tool.

See section 6 Data point lists for more information.



#### CAUTION!

Setting an invalid configuration flag can cause an ETS® configuration alarm in the KNX gateway module. An invalid configuration flag can be one that is not supported or which not allowed to combine with other flags (such as TRANSMIT and WRITE, without READ ON INIT)

See section 7 Troubleshooting for more information.

### CHANGES TO SETTINGS IN TOUCH SCREEN INTERFACE

When the KNX gateway module is enabled in the touch screen interface the following settings are, by default, changed throughout the Smatrix Base PRO system.

- All ECO setback values are set to 0 °C.
- Cooling offset is set to 0 °C.

These changes are limiting the function of Forced ECO, and setpoint offset when changing to cooling mode. The changes to the settings are done to avoid possible conflicts in the touch screen interface if the setpoint is transmitted from the KNX system (i.e. BMS, Building Management System).

However depending on which thermostats are used and how the ETS® configuration flags are set, the system can be setup to behave in different ways.

## MOVE PRO CONTROLLER

### Default ETS® configuration flag settings



#### CAUTION!

If using a BMS to set the heating and/or cooling curve offset (for the zone) it is recommended to change the setting to send setpoint data cyclically, even if the value doesn't change. Otherwise it is recommended to set the setpoint configuration flag to **Read On Init** to secure a fast recovery after startup.

The ETS® configuration flags for each available zone in the Move PRO controller are set, by default, as follows.

- The supply temperature data point is set to COMMUNICATION and TRANSMIT. This enables the thermostat to send the supply temperature (for the zone) to other devices in the KNX system if requested.
- The heating and/or cooling curve offset data points are set to COMMUNICATION and WRITE. This enables the heating and/or cooling curve offset (for the zone) to be overwritten by values from other devices in the KNX system if ordered to.

## UPONOR THERMOSTATS

### Default ETS® configuration flag settings



#### CAUTION!

If using a BMS to set the setpoints of Uponor thermostats it is recommended to change the data point flag to WRITE, and to change the setting to send setpoint data cyclically.

The ETS® configuration flags for an Uponor thermostat are set, by default, to COMMUNICATION and TRANSMIT. This enables the thermostat to send the setpoint (and other values) to other devices in the KNX system if requested.

### Actuator settings in the ETS® tool

It is important that all controller parameter settings in the ETS® tool which are set to “Use with actuator X” (where X is the controller channel number), is referring to an actuator parameter set to “Activated, Uponor thermostat”.

However, if several actuators are controlled by the same Uponor thermostat, only the actuator parameter with the lowest index number is required to be set to “Activated, Uponor thermostat” and still maintain functionality. All other actuator zone settings (registering a thermostat to an actuator channel) are done at the controller in question.

If the KNX gateway module has lost communication with an Uponor controller, all actuator data points in the KNX will be displaying off until the issue is resolved. The actual physical status of the actuator will remain unchanged.

## KNX THERMOSTATS



#### CAUTION!

If using KNX thermostats it is recommended to use thermostats that can send the setpoint and room temperature cyclically, even if the value doesn't change. Otherwise it is recommended to set the setpoint configuration flag to **Read On Init** to secure a fast recovery after startup.

### Default ETS® configuration flag settings

The ETS® configuration flags for a KNX thermostat are set, by default, to COMMUNICATION and WRITE (except the actuator status which is set to COMMUNICATION and TRANSMIT). This enables the thermostat setpoint (and other values, except the actuator status) to be overwritten by values from other devices in the KNX system if ordered to.

### Actuator settings in the ETS® tool

It is important that all controller parameter settings in the ETS® tool which are set to “Use with actuator X” (where X is the controller channel number), is referring to an actuator parameter set to “Activated, KNX thermostat”.

## COOLING OFFSET AND FORCED ECO

### Using only Uponor thermostats in a system (default flag settings)

In this setup only Uponor thermostats are used and all ETS® configuration flags are set to default. Setpoints are transmitted to the controller and touch screen interface, which sends it to the the KNX bus via the KNX gateway module.

Forced ECO and Cooling offset can be activated again in the Uponor system and used without limitations. To activate the functions, ensure that all **ECO setback** values and **Cooling offset** are set to default values (or any other preferred setting).

To enable Forced cooling from the KNX bus, ensure that the parameter setting **Operating mode (Main menu > Heating/Cooling > Operating mode)**, in the touch screen interface, is set to **H/C Master**.

### Using only KNX thermostats in a system (default flag settings)

In this setup only KNX thermostats are used and all ETS® configuration flags are set to default. Setpoints are transmitted to the controller and touch screen interface from the KNX bus via the KNX gateway module.

Forced ECO and Cooling offset is inactive in the Uponor system. Instead the setpoint (already adjusted for Forced ECO or Cooling offset) must be sent from the KNX bus (i.e. from a BMS).

### Using only KNX thermostats, or a mixture of Uponor and KNX thermostats in a system, with Cooling offset activated (requires changed flag settings)

In this setup only KNX thermostats, or a mixture of Uponor and KNX thermostats, are used with Cooling offset activated in the Uponor system. For this setup to work without setpoint conflicts, the KNX thermostat ETS® configuration flags for setpoints must be changed from WRITE to TRANSMIT. Setpoints are now communicated from the controller and touch screen interface to the KNX bus via the KNX gateway module.

Cooling offset (not Forced ECO) can be activated again in the Uponor system and used without limitations. To activate the function, ensure that the setting are set to its default value (or any other preferred setting).

### Forced ECO and Cooling offset in a system is controlled by a BMS (requires changed flag settings)

In this setup Forced ECO and Cooling offset is controlled by a BMS. If any Uponor thermostats are used the ETS® configuration flags for setpoints must be set to WRITE. ETS® configuration flags for any KNX thermostats remain unchanged. Setpoints are transmitted to the controller and touch screen interface from the KNX bus via the KNX gateway module.

Forced ECO and Cooling offset is inactive in the Uponor system. Instead the setpoint (already adjusted for Forced ECO or Cooling offset) must be sent from the KNX bus (i.e. from a BMS).



#### CAUTION!

It is recommended not to use analogue Uponor thermostats (T-143, T-144, and T-145) in this setup.

The BMS cannot overwrite the analogue thermostat setpoints, as they then will revert back to their original analogue settings. This may cause conflict in the Uponor controller creating instability in the system. If the override option is enabled in the interface I-147, the thermostat setpoints cannot be affected by the BMS.

## 6 Data point lists

Uponor provides default configuration flags (in the product data file) which normally does not need to be changed.

General parameters				Configuration flags, group objects					
Data point	Description	ID	KNX data type	C	T	W	R	U	ROI
Outdoor temperature	Measured outdoor temperature	1	DPT_Value_Temp	X	X				
Forced ECO	System setback control	2	DPT_HVACMode	X	*	X*			
Operating Mode (Auto/H/C)	Heating/Cooling control	3	DPT_HVACContrMode	X	*	X*			
Controller pump/boiler status	Relay status: 0 = Open, 1 = Closed	63, 112, ***, 749, 798	DPT_Switch	X	X				

Zone (circuit) parameters				Configuration flags, group objects					
Data point	Description	ID	KNX data type	C	T	W	R	U	ROI
Circuit 1, supply temperature	Measured supply temperature	4	DPT_Value_Temp	X	X				
Circuit 1, heating curve offset	Heating curve offset	5	DPT_Value_Temp	X	*	X*			
Circuit 1, cooling curve offset	Cooling curve offset	6	DPT_Value_Temp	X	*	X*			
Circuit 2, supply temperature	Measured supply temperature	7	DPT_Value_Temp	X	X				
Circuit 2, heating curve offset	Heating curve offset	8	DPT_Value_Temp	X	*	X*			
Circuit 2, cooling curve offset	Cooling curve offset	9	DPT_Value_Temp	X	*	X*			
Circuit 3, supply temperature	Measured supply temperature	10	DPT_Value_Temp	X	X				
Circuit 3, heating curve offset	Heating curve offset	11	DPT_Value_Temp	X	*	X*			
Circuit 3, cooling curve offset	Cooling curve offset	12	DPT_Value_Temp	X	*	X*			
Circuit 4, supply temperature	Measured supply temperature	13	DPT_Value_Temp	X	X				
Circuit 4, heating curve offset	Heating curve offset	14	DPT_Value_Temp	X	*	X*			

Room parameters (X = 1–16, Y = 1–12)				Configuration flags, group objects					
Data point	Description	ID	KNX data type	C	T	W	R	U	ROI
Uponor Room X.Y temperature	Measured room temperature		DPT_Value_Temp	X	X				
Uponor Room X.Y set point	Room setpoint temperature	15	DPT_Value_Temp	X	X**	**			
Uponor Room X.Y actuator	Actuator status: 0 = Closed, 1 = Open	– 797	DPT_BinaryValue	X	X				
Uponor Room X.Y relative humidity	Measured relative humidity level (%)		DPT_Value_Humidity	X	X				
KNX Room X.Y temperature	Measured room temperature		DPT_Value_Temp	X		X			
KNX Room X.Y set point	Room setpoint temperature	15	DPT_Value_Temp	X	**	X**			
KNX Room X.Y actuator	Actuator status: 0 = Closed, 1 = Open	– 797	DPT_BinaryValue	X	X				
KNX Room X.Y relative humidity	Measured relative humidity level (%)		DPT_Value_Humidity	X		X			

\* The TRANSMIT and WRITE flags cannot be combined without causing an error in the KNX gateway module, unless the READ ON INIT flag is set as well.

\*\* The TRANSMIT and WRITE flags is not recommended to be combined, unless the READ ON INIT flag is set as well.

\*\*\* The ID for each controller in order: 63, 112, 161, 210, 259, 308, 357, 406, 455, 504, 553, 602, 651, 700, 749, 798.



**AVAILABLE ETS® CONFIGURATION FLAGS**

Flag		Description
COMMUNICATION	C	Enables the KNX gateway module to communicate with the data point.  Must always be activated when the data point is used.
TRANSMIT	T	Enables the KNX gateway module to transmit Smatrix Base PRO data points to the KNX bus.
WRITE	W	Enables the KNX gateway module to write KNX data points to Smatrix Base PRO system bus.
READ	R	Enables the KNX gateway module to respond to read requests from other device data points.
UPDATE	U	Enables the KNX gateway module to overwrite a data point with read data after sending a READ, or READ ON INIT, request to another data point.
READ ON INIT	ROI	Enables KNX gateway module to do a read on init request for data points on the KNX bus.

**CAUTION!**

Setting an invalid configuration flag can cause an ETS® configuration alarm in the KNX gateway module. An invalid configuration flag can be one that is not supported or which not allowed to combine with other flags (such as TRANSMIT and WRITE, without READ ON INIT)

*See section 7 Troubleshooting for more information.*

## 7 Troubleshooting

### 7.1 KNX gateway module LEDs

It is recommended to occasionally check the status LEDs on the KNX gateway module for alarms.

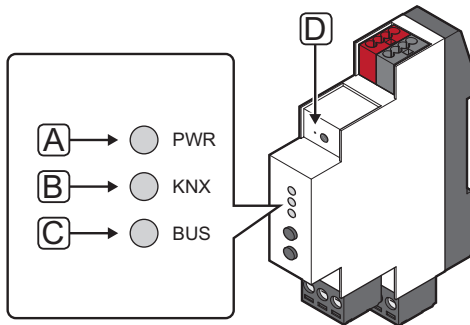

Item	Description
A	Power LED
B	KNX LED
C	Modbus LED
D	Programming LED

The table below describes the status of the KNX gateway module LEDs.

LED	Status
Power	<p>The power LED is always on.</p> <ul style="list-style-type: none"> <li>Red, on – software initialisation after power on</li> <li>Green, on – KNX gateway module is initialised</li> </ul>
KNX	<p>The KNX LED is always on.</p> <ul style="list-style-type: none"> <li>Red, on – error, or software initialisation after power on</li> <li>Green, on – KNX gateway module is connected and setup vid KNX</li> <li>Red or green flashing – data is received via KNX bus</li> </ul>
Modbus	<p>The Modbus LED is always on.</p> <ul style="list-style-type: none"> <li>Red, on – error, or software initialisation after power on</li> <li>Green, on – KNX gateway module is connected and enabled via Modbus</li> <li>Red or green flashing – data is received via Modbus</li> </ul>
Programming	<ul style="list-style-type: none"> <li>Red, on – KNX gateway module in programming mode</li> <li>Off – KNX gateway module not in programming mode</li> </ul>

### 7.2 KNX gateway module error codes

If an error in the KNX gateway module has occurred during normal operation, the bus LED (KNX and/or Modbus) changes to red.

To get more information about the error press the button for the bus where the error is indicated. When pressed, the bus LED flashes green a number of times, indicating an error code. Only the first error is shown, if multiple errors has occurred they must be resolved in order until the LED is green again.

See section 7.4 LED Error codes for more information.

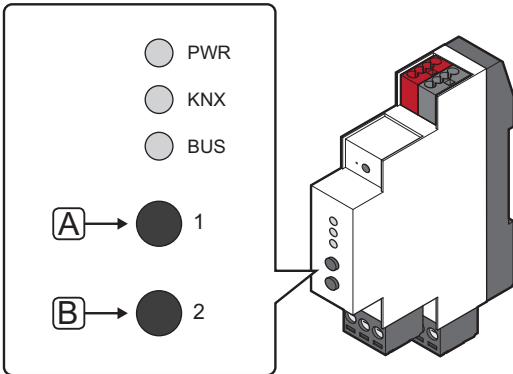

Item	Description
A	Button 1 – KNX
B	Button 2 – Modbus

### 7.3 Resetting the KNX gateway module

If the KNX gateway module does not work as expected, or if an error is indicated, it can be reset and maybe solve the problem.

When reset, the KNX gateway module gets the configuration from the KNX bus and pushes it to the Smatrix Base PRO controllers. By doing so it is ensured that any faults due to something being wrong with the configuration is removed.

See section 7.4 LED Error codes for more information.

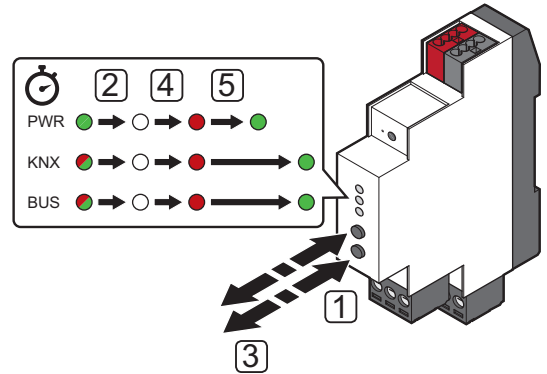

To reset the KNX gateway module:

1. Press and hold buttons 1 and 2 for at least 10 seconds.
2. All LEDs is turned off.
3. Release buttons 1 and 2.
4. All three LEDs light up red again and the KNX gateway module starts up again.
5. The power LED changes from red to green after a couple of seconds. The Modbus and KNX LEDs follows shortly when initialised.

**NOTE!**

A flashing LED indicates that the KNX gateway module receives data via Modbus and/or KNX.

## 7.4 LED error codes

### KNX ERROR CODES

The table below shows error codes for the KNX bus and describes possible solutions. A common cause of a problem though may be due to faulty wiring.

Error code	Description	Probable cause	Solutions
1	Get ETS® configuration	The KNX gateway module has not yet received configuration from the ETS® tool.	<p>Ensure the KNX gateway module is installed correctly and that it has been programmed by the ETS® tool.</p> <p>If the error persists, perform a hard reset on the KNX gateway module. <i>See section 7.3 Resetting the KNX gateway module for more information</i></p>
2	Invalid ETS® flag	An invalid manual configuration flag has been set on KNX group objects in ETS®.	<p>Ensure all manual configuration flags on KNX group objects in ETS® are correct.</p> <p>Example: Activated data points which are only readable from KNX must have READ or TRANSMIT flags set.</p> <p>If many changes had been done in ETS® before the error occurred, Uponor recommends to remove all COMMUNICATION flags from multiple group objects at once. Then to add them one by one until the error occurs again.</p> <p><i>See section 6 System setup for more information.</i></p>
3	Incorrect ETS® actuator configuration	A parameter setting in the ETS® for actuator control is incorrect.	<p><b>When using KNX thermostats</b></p> <p>Ensure that all controller parameter settings, which are set to “Use with actuator X” (where X is the controller channel number), is referring to an actuator parameter set to “Activated, KNX thermostat”.</p> <p><b>When using Uponor thermostats</b></p> <p>Ensure that all controller parameter settings, which are set to “Use with actuator X” (where X is the controller channel number), is referring to an actuator parameter set to “Activated, Uponor thermostat”.</p> <p>However, if several actuators are controlled by the same Uponor thermostat, only the actuator parameter with the lowest index number is required to be set to “Activated, Uponor thermostat” and still maintain functionality. All other actuator zone settings (registering a thermostat to an actuator channel) are done at the controller in question.</p>
4	Occupied thermostat channel	A KNX thermostat is registered on the same channel as an Uponor thermostat.	<ol style="list-style-type: none"> <li>1. Ensure that an Uponor thermostat is not registered to a channel used by a KNX thermostat.</li> <li>2. Unregister the Uponor thermostat from the controllers or reprogram the KNX thermostat to an unused channel in the ETS® tool.</li> <li>3. If the error persists, perform a hard reset on the KNX gateway module. <i>See section 7.3 Resetting the KNX gateway module for more information.</i></li> </ol>
5	Slave channel not available	A KNX thermostat is registered to a channel on an unavailable slave module.	<p>Ensure that the controller has a slave module installed (the controller only have 6 channels by default).</p> <p>If a slave module isn't available, allocate the KNX thermostat to another channel in the ETS®.</p>
6	KNX Thermostat lost	A KNX thermostat has timed out. The KNX gateway module hasn't received data from a KNX thermostat for at least 6 hours.	<ol style="list-style-type: none"> <li>1. Ensure that the KNX thermostats are connected to the KNX bus.</li> <li>2. Ensure that the parameter settings for the KNX thermostats in the ETS® are correct.</li> <li>3. Ensure that the thermostats, if possible, are set to send room temperature cyclically. Otherwise decrease the temperature difference parameter which is allowed before sending a new value via the KNX bus.</li> </ol>

## MODBUS ERROR CODES

The table below shows error codes for Modbus. A common cause of a problem though may be due to faulty wiring.

Error code	Description	Probable cause	Solutions
1	KNX gateway module and Smatrix Base PRO Master controller error	The KNX gateway module has not received transmission from the master controller for a period of time.	<ol style="list-style-type: none"> <li>1. Ensure that the master controller is connected to a power source.</li> <li>2. Ensure that a touch screen interface is registered to the master controller.</li> <li>3. Ensure that the Modbus connectors on the master controller and the KNX gateway module are connected and wired correctly.</li> </ol>
2	Touch screen interface configuration error	<p>The KNX gateway module has not received transmission from the touch screen interface for a period of time.</p> <p>A cooling request has been sent to the KNX gateway module from the KNX bus, but cooling is not setup correctly in the touch screen interface.</p>	<p>Ensure that the KNX gateway module is enabled in the touch screen interface.</p> <p><i>See section 4.11 Enable the KNX gateway module in the interface I-147 for more information.</i></p> <p>Ensure that the parameter setting Operating mode (<b>Main menu &gt; Heating/Cooling &gt; Operating mode</b>) is set to <b>H/C Master</b>.</p>
3	Restarting controller	An Uponor controller, in the system, has restarted but has not been able to communicate with the KNX gateway module yet.	<p>The alarm should be reset automatically, when the KNX gateway module communicated with the restarted Uponor controller again. How long it takes is dependent on how many Uponor controllers are present in the system.</p> <p>If the alarm is persistent (not automatically reset):</p> <ol style="list-style-type: none"> <li>1. Ensure that all Uponor controllers in the system is powered up.</li> <li>2. Perform a hard reset on the KNX gateway module.</li> </ol> <p><i>See section 7.3 Resetting the KNX gateway module for more information.</i></p> <ol style="list-style-type: none"> <li>3. Ensure that the numbers of Uponor controllers set in the ETS® tool match the actual number of controllers installed in the system.</li> </ol>
4	Touch screen interface and Smatrix Base PRO controller communication error	The touch screen interface has not received transmission from one of the controllers for a period of time.	<ol style="list-style-type: none"> <li>1. Ensure that all Uponor controllers in the system is powered up.</li> <li>2. Perform a hard reset on the KNX gateway module.</li> </ol> <p><i>See section 7.3 Resetting the KNX gateway module for more information.</i></p> <ol style="list-style-type: none"> <li>3. Ensure that the numbers of Uponor controllers set in the ETS® tool match the actual number of controllers installed in the system.</li> </ol>
5	Touch screen interface and Smatrix Move PRO controller communication error	The touch screen interface has not received transmission from the Smatrix Move PRO controller for a period of time.	<ol style="list-style-type: none"> <li>1. Ensure that the Smatrix Move PRO controller is powered up.</li> <li>2. Check the Smatrix Move PRO controller Modbus wiring and ensure it is correct.</li> </ol>

Error code	Description	Probable cause	Solutions
6	KNX gateway module and Smatrix Base PRO controller communication error	The KNX gateway module has not received any communication replies from one of the controllers for a period of time.	<ol style="list-style-type: none"> <li>1. Ensure that all Uponor controllers in the system is powered up.</li> <li>2. Perform a hard reset on the KNX gateway module. <i>See section 7.3 Resetting the KNX gateway module for more information.</i></li> </ol>
7	KNX gateway module and Smatrix Move PRO controller communication error	The KNX gateway module has not received any communication replies from the Smatrix Move PRO controller for a period of time.	<ol style="list-style-type: none"> <li>1. Ensure that the Smatrix Move PRO controller is powered up.</li> <li>2. Check the Smatrix Move PRO controller Modbus wiring and ensure it is correct.</li> </ol>
8	KNX configuration of Uponor controller	<p>The KNX gateway module has been programmed with the ETS<sup>®</sup> tool and all available Uponor controllers gets new KNX configuration.</p> <hr/> <p>One or more of the available Uponor controllers have restarted. A restart triggers a transmission of the KNX configuration to all connected devices.</p>	<ol style="list-style-type: none"> <li>1. Ensure that all Uponor controllers in the system is powered up.</li> <li>2. Perform a hard reset on the KNX gateway module. <i>See section 7.3 Resetting the KNX gateway module for more information.</i></li> <li>3. Check the KNX bus for errors which might affect the Uponor controllers.</li> </ol>

## 8 Technical data

### 8.1 Technical data

General	
IP	IP20 (IP: degree of inaccessibility to active parts of the product and degree of water)
Operating temperature	-5 °C to +45 °C
Storage temperature	-25 °C to +70 °C
Relative humidity (non-condensing)	5 % to 93 %
Weight	55 g
CE marking	
EAC marking	
Tests according to	Low Voltage Directive 2014/35/EU EMV Directive 2014/30/EU RoHS Directive 2011/65/EU <ul style="list-style-type: none"> <li>• EN 50581: 2012</li> <li>• EN 50491-5-1: 2010</li> <li>• EN 50491-5-2: 2010</li> <li>• EN 50491-5-3: 2010</li> <li>• EN 61000-6-2: 2005</li> <li>• EN 61000-6-3: 2007 + A1: 2011</li> </ul>
KNX	
KNX connection	29 V DC
KNX bus current consumption	10 mA
Compatible with ETS®	ETS® version 5 (or higher)
Modbus	
Power supply	5 V DC from controller thermostat bus
Modbus connection	A, B, – on controller system bus



<http://www.uponor.com/ce-compliance>

## 8.2 Wiring diagram

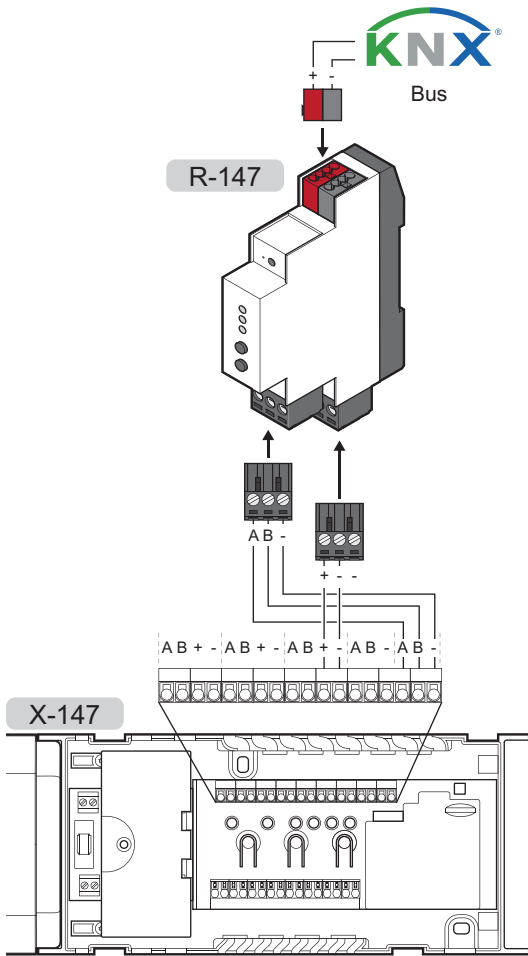

## 8.3 Dimensions

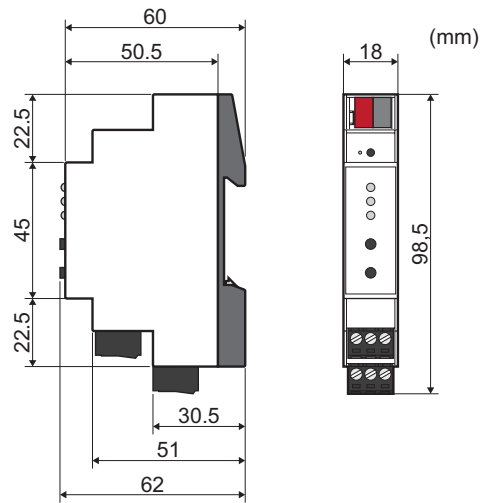





A series of horizontal dotted lines spanning the width of the page, providing a guide for writing notes or instructions.



**Uponor Corporation**  
[www.uponor.com](http://www.uponor.com)

Uponor reserves the right to make changes, without prior notification, to the specification of incorporated components in line with its policy of continuous improvement and development.

**Uponor**