TEPE BETOPAN

Application Manual

2017

The logo for tepePAN, featuring a stylized mountain peak with a green and grey color scheme.

tepePAN®

The logo for TEPE BETOPAN, featuring a stylized mountain peak with a grey and red color scheme.

TEPE
BETOPAN®

Application Manual



1783-CPR-189



TS EN 13986



TEPE BETOPAN

Application Manual

2017

CONTENTS

"The time you see change, it is TEPE Betopan"

Turkey's First Building Panel

4

Interior Building Panels

6

Betopan

8

1984

The first Building Panel in Turkey

Our factory was established in 1984 under the registered brand of Betopan®. The factory was built in Ankara Beytepe Facilities. It became the first company to produce particle board with cement in Turkey through establishing its manufacturing facilities in Ankara/Beytepe under brand name betopan®

Technical Features of Betopan®

10

Tepepan

12

Technical Features of Tepepan®

14

Principles of Implementation

16



The company is the sole producer of particle board with cement in Turkey and one of the few companies in the world a production capacity of 50.000 m²/year



As a result of the R&D conducted by our company in 2001, the existing panel was redesigned and recreated to make it become more stable and durable. The name of the product is Betopanplus®, that is now a part of product range.

42

Wall Systems

44

Omega Profile Application

40

Under Eaves, Facades, Balconies and Terrace Ceilings

41

Elevator Shafts
Fire Escape Doors

39

Wet Area Application

38

Roof Application

37

Raised Flooring Application

36

Suspended Ceiling Application

33

Mezzanine Application

"The time you see change, it is TEPE Betopan"

CONTENTS

<p>Assembly Parts 18</p> <p>Cutting Process 19</p> <p>Detailed Photographs 20</p> <p>Painting Process 26</p> <p>Application Fields 28</p> <p>Wall Application 30</p> <p>Ground Application 32</p> <p>Mezzanine Application 33</p>			
<p>2001</p> <p>Following the positive results of the features of Betoplanplus® on external facades, it was used in the same machine park but with a different production method to design and produce yalıpan® with added wood texture and taşonit® with added stone texture.</p>	<p>2011</p> <p>With the unique textures of these panels it became possible to create different external facade applications. Due to the variations that could be created with accessories and inclusive insulation, the demand for Monolin®, Frapan® and Fugalin® with linear decorative texture grew rapidly which production started in 2011 followed by the cut stoned design Tuğpan® and brick design Tuğlapan® in 2012.</p>	<p>2014</p> <p>With an established principle to produce nature friendly and healthy products utilizing an accumulation of knowledge, Tepe Betopan® began producing its new fibercement product TepePAN® in 2014, during the company's 30th year.</p>	<p>2015</p> <p>Tepe Betopan had become an example for the industry with its social responsibility projects taht have been implemented in Turkey. With its respect for the environment, ethics and quality, it is also jointed to the world one and only government supported</p>
<p>45</p> <p>Standart Jointed, Grooved Application</p>	<p>66</p> <p>External Façade Building Panels</p>	<p>70</p> <p>BetopanPlus Technical Features</p>	<p>72</p> <p>Yalıpan</p>
<p>68</p> <p>BetopanPlus</p>	<p>73</p> <p>Taşonit</p>	<p>74</p> <p>Monolin</p>	<p>75</p> <p>Frapan</p>
<p>76</p> <p>Fugalin</p>	<p>77</p> <p>Tuğpan</p>	<p>78</p> <p>Tuğlapan</p>	<p>TURQUALITY® - Brand Program to maintain its presence in the international arena, continue sustainable development and contribute to the positive image of "Turkish Products" in line with the Ministry of Economy's vision to "Create 10 Brands in 10 Years".</p>
<p>80</p> <p>Accessories</p>	<p>82</p> <p>Application Types</p>	<p>84</p> <p>Grooved Application</p>	<p>88</p> <p>Fluted Applications</p>
<p>94</p> <p>Classic Connected Application</p>	<p>100</p> <p>Corded Application</p>	<p>106</p> <p>Dimensional Application</p>	<p>112</p> <p>P. Sampels</p>
<p>124</p> <p>Transport Principles</p>	<p>126</p> <p>Bilkent Holding</p>		

Tepe Betopan A.Ş., the company that produced Turkey's first building panels and became the leader in this field, established a factory in its Ankara Beytepe facility to start producing the first particle boards with cement in Turkey under the Betopan® brand in 1984. Starting out with a two layer air application system with 25,000 m³ capacity, a renewal investment was added at the end of 1999 to switch to a three layered mechanical application system developed within the structure of the company to increase the capacity to 35,000m³. With the purchase of the other cement particle board factory in Arhavi in 2001, the company became the sole producer in Turkey and one of the few selected producers in the world. With the revision of some machines and equipment in 2006 and the addition of some new machines and the machine line located in Arhavi being relocated in 2008 to Ankara Bilkent, the production and dispatch volume was collected under a single point and the annual production capacity was increased to 67,500 m³.

In 2001, with new products aimed for outer façade use, Tepe Betopan completely removed particle board from its panel outer layers and in replaced it with layers made of inorganic granule and cement mortar. Thus, in addition to the cement particle board betopan® the company has been producing and selling since 1984, the production and sale of betopanplus® was started as a first in the sector. The most important feature of this new panel with the patent registered as betopanplus® is that it reduces movement connected to relative humidity and the effects of the sun by 55-60% and creates surfaces that are more durable against outdoor effects. During the same period, due to the positive results of using the advanced features of flat surface betopanplus® on outer facades, a different method of production was used with the same machine park and system to design and produce the products yalipan® with a wood texture on the surface and taşonit® with a stone texture on the surface. By applying these panels with unique textures to different designs, varying external façade appearances were achieved.

**BETOPAN FACTORY**

Due to the great interest and demand for outer façade insulation in mid 2011, Tepe Betopan designed and added to its product range monolin®, frapan® and fugalın® followed by the cut stone design Tuğpar® and brick design alternated Tuğlapan® in 2012. Tepe Betopan started to produce another type of fibercement panel at its new LEED Gold Certified facility in Ankara Temelli established with an investment of 32 million USD in the last quarter of 2014. When the new generation fibercement tepePAN® joined the family Tepe Betopan had become the only producer in Turkey and one of a few selected producers in the world to produce fibercement panels and particle board with cement at the same facility. With over 30 years of experience in panels with cement, Tepe Betopan, which has reinforced tepePAN® for outer façade use continues its leadership in the sector and continues to raise the cement panel standards in the sector.*

In addition to the information given above Tepe Betopan A.Ş. is a company that has set an example for the sector with its social responsibility projects that have been implemented in Turkey, with its respect for the environment and its work ethics and quality. It has also joined the world's one and only government supported brandization program the TURQUALITY® - Brand Program to maintain its presence in the international arena, continue sustainable development and contribute to the positive image of "Turkish Products" in line with the Ministry of Economy's vision to "Create 10 Brands in 10 Years". In line with the contributions it has provided with the TURQUALITY® - Project, Tepe Betopan will continue its work with increasing speed to achieve distinctive innovations in the sector with its motto of "when you see change; it is Tepe Betopan..."

**The LEED(Leadership in Energy and Environmental Design) Gold Certificate: Is an Environmentally Conscious Building Certificate created by the USGBC (US Green Building Committee) which is most preferred in the world and in Turkey.*





INTERIOR BUILDING PANELS



BETOPAN THE SOLIDNESS OF CONCRETE

These are cement based panels that are comprised of particle board and a combination of harmless chemicals. They are suitable for use in the interior or exterior of any kind of structure. Some of the advantages provided by Betopan, a material that is preferred for all field requiring high resistance, are as follows;

- ✓ Advanced inflammability,
- ✓ Resistance to damp, moisture and water,
- ✓ Very limited capillarity,
- ✓ Durable against movement related to relative humidity,
- ✓ Insulates against airborne noise,
- ✓ Durable against biological waste,
- ✓ Impact resistant,
- ✓ Resistant to insects, termites and fungus,
- ✓ Durable in waterside conditions,
- ✓ Resistant to harsh weather conditions like sun and frost
- ✓ Easy to process and assemble,
- ✓ Does not contribute to fire,
- ✓ Does not emit toxic fumes during a fire,
- ✓ Has very low water absorption and water swelling rate,
- ✓ As it is a finished material, it does not require plaster, only painting is sufficient.
- ✓ It has natural content and is harmless to health.

MEASUREMENTS

Thickness: 8/10/12/14/16/18/20/24/30 mm

Width: 1250 mm

Length: 2500/2800/3000 mm

Special Dimensions: Special cuts can be made as needed to accommodate width and length needs.



FIELDS OF USE

- ✓ On outer façade cladding,
- ✓ On interior of areas like shops, galleries, store windows and studios (for decoration),
- ✓ As a background panel in advertisements,
- ✓ In the building of site fences,
- ✓ In electrical transformers,
- ✓ Under ceramic and plaster (as background panels),
- ✓ In CNC incorporating patterns (for decoration),
- ✓ In fire doors and escape corridors,
- ✓ In building fire prevention walls,
- ✓ In the base of suspended floors as a load bearing floor and under flooring,
- ✓ As an under panel for a roof cover,
- ✓ As elevated flooring panels,
- ✓ On the walls of elevator shafts and fire escape walls,
- ✓ On the floor and walls of animal shelters,
- ✓ In greenhouse floors and walls,
- ✓ In building pressed wall panels with internal insulation,
- ✓ Under building eaves and eave panels,
- ✓ Can be used as frame accessories on door and window frames
- ✓ In floor, wall and ceiling applications of prefabricated structures,
- ✓ As a suspended ceiling panel.



BETOPAN

TECHNICAL FEATURES



TECHNICAL SPECIFICATIONS	Standards it is subject to	Betopan® brand Particle Board Panels with Cement According to Unsanded TS EN 634-1-2	Betopanplus® brand Unsanded, TS EN 634-1-2 Elastic Module 1st Class, Non-Particle Surfaces, Particle Board Panels with Cement
Unit Volume Weight (Material Dampness)	TS EN 634-2, TS EN 323	1300 ± 50 kg / m ³	1450 ± 75 kg / m ³
Elastic Module in Bending	TS EN 634-2, TS EN 310	≥ 9 N/mm ²	≥ 9 N/mm ²
Elastic Module in Bending	TS EN 634-2, TS EN 310	≥ 4500 N/mm ² (Sınıf 1)	≥ 4500 N/mm ² (Sınıf 1)
Tensile Strength:			
Vertical to Surface	TS EN 634-2, TS EN 319	≥ 0,5 N/mm ²	≥ 0,5 N/mm ²
Wear in Damp Setting	TS EN 634-2, TS EN 321, TS EN 319	≥ 0,3 N/mm ²	≥ 0,3 N/mm ²
Vertical to Surface after Test			
Parallel to Surface	TS EN 789	≥ 4 N/mm ²	
Pressure Resistance (Parallel to Surface)	TS EN 789	≥ 15 N/mm ²	
Swelling on Thickness:			
After waiting 24 hours	TS EN 634-2, TS EN 317	≤ % 1,5	≤ % 1,5
After Wear in Damp Testing	TS EN 634-2, TS EN 321, TS EN 317	≤ % 1,5	≤ % 1,5
Screw withdrawal power:			
At 10 mm thickness	TS EN 1380	168 N for 4.2x65 mm screw	
At 18 mm thickness	TS EN 1380	300 N for 4.2x65 mm screw	
Material Dampness	TS EN 634-1, TS EN 322	% 9 ± 3	% 9 ± 3
Wood pests	TS EN 335-3	The risk of being affected by all wood pests is negligible*	The risk of being affected by all wood pests is negligible*
Formaldehyde emission		No substance containing formaldehyde is used in production (E1).	No substance containing formaldehyde is used in production (E1).
Asbestos		No material containing asbestos is used in prod.	No material containing asbestos is used in prod.
Tolerances:			
Thickness	TS EN 634-1, TS EN 324-1	08-10 mm ± 0,7 mm 12-14 mm ± 1,0 mm 16-18 mm ± 1,2 mm >18 ± 1,5 mm	08-10 mm ± 0,7 mm 12-14 mm ± 1,0 mm 16-18 mm ± 1,2 mm >18 ± 1,5 mm
Length and Width	TS EN 634-1, TS EN 324-1	Length: ±5 mm Width: ±5 mm	Length: ±5 mm Width: ±5 mm
Smoothness of edges	TS EN 634-1	≤1,5 mm / m	≤1,5 mm / m
Verticalness of corners	TS EN 634-1	≤2 mm / m	≤2 mm / m
Standard Measurements and Weights		Thickness(mm): 08,10,12,14,16,18,20,24,30 Weight (kg/m ²): 10,13,15,18,20,23,26,31,39 Width (mm): 1250 Length (mm): 2500, 2800, 3000	Thickness(mm): 08,10,12,14,16,18 Weight (kg/m ²): 12,15,18,21,24,27 Width (mm): 1250 Length (mm): 2500, 2800, 3000
Heat Conductivity (λ)	TS EN 12664	0,15-0,16 W/mK	0,19 W/mK
Heat Expansion Ratio (µm / mK):			
For 10 mm thickness	DIN 51045	11.5	
For 18 mm thickness	DIN 51045	11.6	
Reaction to Fire (European Standard)	DIN EN 13501-1, DIN EN 13823, DIN EN ISO 11925-2	Fire: B, Smoke:s1, Sparkin Particles:d0	Fire: A2, Smoke:s1, Sparkin Particles:d0
Reaction to Fire (United Kingdom Class)	United Kingdom Building Regulation Document B2	"Snif O" European Class B s3, equivalent to d2 (no class in s3 smoke, in d 2 sparking particles)	"Snif O" European Class B s3, equivalent to d2 (no class in s3 smoke, in d 2 sparking particles)
Resistance to Fire Period	TS 1263 (DIN 4102-2)	Thickness (mm): 08, 10, 12, 14, 16, 18 Period (mins): 31, 32, 34, 35, 37, 39	
Linear stability connected to relative moisture (RH)(mm/m)			
In the shade:			
8-12 mm thickness	TS EN 318	-1,0 (%65---> %35 RH) +0,4 (%65---> %85 RH)	
14-18 mm thickness	TS EN 318	-1,4 (%65---> %35 RH) +0,3 (%65---> %85 RH)	
In Sun:			
12 mm panels conditioned at 85% ±5 RH and 20±2°C in Ankara, southern front, after 1 year, at the end of the summer, each 300 gr/m ² on both			
Water based color + Water based cla		-2,3	-1.5
Water based silicon principle paint		-2,5	-1.7
Sound Permeability (R)	TS EN 13986	10 mm thickness 29dB 10 mm thickness 32dB	12 mm thickness 31dB 18 mm thickness 33dB
Sound Absorption:			
250 Hz - 500 Hz arası	TS EN 13986	0.10	
1000 Hz - 2000 Hz arası		0.30	
pH		11-13	
Water Steam Permeability (µ):			
At 10 mm thickness	TS EN 13986	Dry Plate = 50 Wet Plate = 30	
At 18 mm thickness	TS EN 13986	Dry Plate = 50 Wet Plate = 30	

The fiber based cement panels are comprised of cement and cellulose as well as some harmless chemicals. With high resistance to fire, these environmentally friendly panels are suitable for use in all internal and external facades of any type of structure. Preferred in all fields that require high durability some of the other benefits that TepePAN® provides can be listed as below;

- ✓ No harmful chemicals, included
- ✓ Excellent sound and heat insulation,
- ✓ Ideal for prefabricated structures,
- ✓ Does not swell or mold in water,
- ✓ Does not get affected by damp,
- ✓ Not plastic,
- ✓ Does not get infested,
- ✓ Being non-flammable
- ✓ Fast and easy assembly

MEASUREMENTS

Thickness: 6/8/10/12/14 mm

Width: 1250 mm

Length: 2500/2800/3000 mm

Special Dimensions: Special cuts can be made to accommodate width and length needs.



FIELDS OF USE

- ✓ On the internal and external walls of any type of structure,
- ✓ On aerated façade cladding systems,
- ✓ On insulated cladding systems,
- ✓ On prefabricates and light steel structure surfaces,
- ✓ Building section of structures made of steel construction,
- ✓ It is already finished product, which afterwards requires only painting depending on the choice.
- ✓ Panels under all coating, wallpaper or ceramic in internal and external areas (as backer board),
- ✓ Under tiles in wet areas
- ✓ On ceiling coatings of indoor and outdoor areas,
- ✓ Suspended ceiling systems,
- ✓ On making fire walls,
- ✓ In places where sound insulation is needed,
- ✓ On heat insulation systems,
- ✓ As over roof covering under panels,
- ✓ As support material for cabinets and panels,
- ✓ On walls, parapets and ceilings of balconies,
- ✓ On eave panels and under eaves,
- ✓ On steel and fake column coatings,
- ✓ On construction of site fencing,
- ✓ On shaft walls,



Tepepan Technical Specifications

Product Type	Autoclaved, cellulose reinforced, cement boards.
Product Properties	Resistant all type of weather conditions. Easily machinable by hard wood working tools.
Board Dimensions	1250 x 2500-2800-3000 mm
Thickness	6-8-10-12-14 mm
Min. Dry Weight	7,2-9,6-12-14,4-16,8
Tolerance in Length	± 5 mm (TS EN 12467)
Tolerance in Width	± 3,75 mm (TS EN 12467)
Tolerance in Thickness	± %10 t (t: board thickness)
Deviation in Perpendicularity on Edges	≤ ± 2mm/m (TS EN 12467)
Deviation in Straightness on Edges	≤ 0,1 % x edge length
Surface Appearance	Untextured
Dry Apparent Density	min 1200 kg/m ³ (1,2 g/cm ³)
Bending Strength	≥ 7 N/mm ² (Average of the values parallel and perpendicular to the direction of production in wet conditions) ≥ 12 N/mm ² (Average of the values parallel and perpendicular to the direction of production in ambient laboratory conditions)
Compressive Strength	> 35 MPa (After 24 hours of conditioning in 20 ± 2 °C water) > 40 MPa (After 7 days of conditioning in laboratory)
Frost Resistance	It is resistant to frost according to TS EN 12467
Water Resistance	Resistant to water (According to TS EN 12467)

Tepepan Technical Specifications

Fire Resistance	Non-combustible, A1 Class (According to EN 13501-1)
Asbestos	Asbestos free, according to TS EN 12467
pH	10,5 - 12
Formaldehyde Emission	It does not contain any Formaldehyde adhesive
Coefficient of Thermal Conductivity	$\lambda = 0,2166 \text{ W/mK}$ (TS EN 12667)
Thermal Resistance	$46,168 \times 10^{-3} \text{ m}^2\text{K/W}$ (10 mm için), $55,401 \times 10^{-3} \text{ m}^2\text{K/W}$ (12 mm için) (TS EN 12667)
Coeff. of Thermal Expansion	0,00493 mm/mK (DIN 51045)
Modulus of Elasticity	$\geq 4000 \text{ N/mm}^2$ Average of the values parallel and perpendicular to the direction of production in ambient laboratory conditions
Water Absorbtion	2 hours, by weight <15% (Of a board in ambient laboratory conditions) 24 hours, by weight <25% (Of a board in ambient laboratory conditions)
Porosity	< 30% (Of a board in ambient laboratory conditions)
Water Vapor Permeation Resistance	$\mu = 13,31$ (TS EN ISO 12572)
Mean Water Vapor Resistance Value [Z]	0,187 $\text{m}^2\text{hPa/mg}$ (TS EN 12086)
Moisture Movement 30-90% Relative Humidity	0,05%
Increase in Thickness	< 1 % (After 24 hours in water)
Heating – Rain Effect	When tested in accordance with TS EN 12467, no visible cracks, delamination, warpage and deflection or other faults which can affect the performance in use occur after 50 heat – rain cycles.
Hot Water Effect	It is resistant to hot water according to TS EN 12467
Soaking - Drying	It is resistant to soaking and drying according to TS EN 12467



APPLICATION PRINCIPLES



APPLICATION PRINCIPLES

Tepe Betopan products are functional which can be used in all indoor and outdoor areas from the foundation to the roof of all structures. The durability, lightness, processability and availability of the panels make them also a preferred product in other sectors besides construction like poultry farming, greenhouses, fisheries, etc. In this section the applications done with cement based panels and the principles for these applications are explained. The instructions have been provided based on the type of application to guide the user to the right product, product thickness and suggested application principles.

The General Fields of Use for Patternless Panels

- ✓ Outer walls,
- ✓ Internal dividing walls,
- ✓ Backer board applications,
- ✓ Internal wall cladding applications,
- ✓ Wet areas,
- ✓ Load bearing ground,
- ✓ Suspended ceilings,
- ✓ Under eaves and eave faces,
- ✓ Roofs,
- ✓ Elevator shafts,
- ✓ Insulated wall panels (press panels)
- ✓ Fire doors,



ASSEMBLY ELEMENTS

We have tried to explain in detail some assembly part that are used some assembly parts are used in the applications we have tried to explain in detail here in this booklet. Since one type of application can be done in several different ways, different assembly parts can be used for the same application. When choosing the assembly parts like screws, profiles and dowels caution should be shown to select quality, rust proof products.

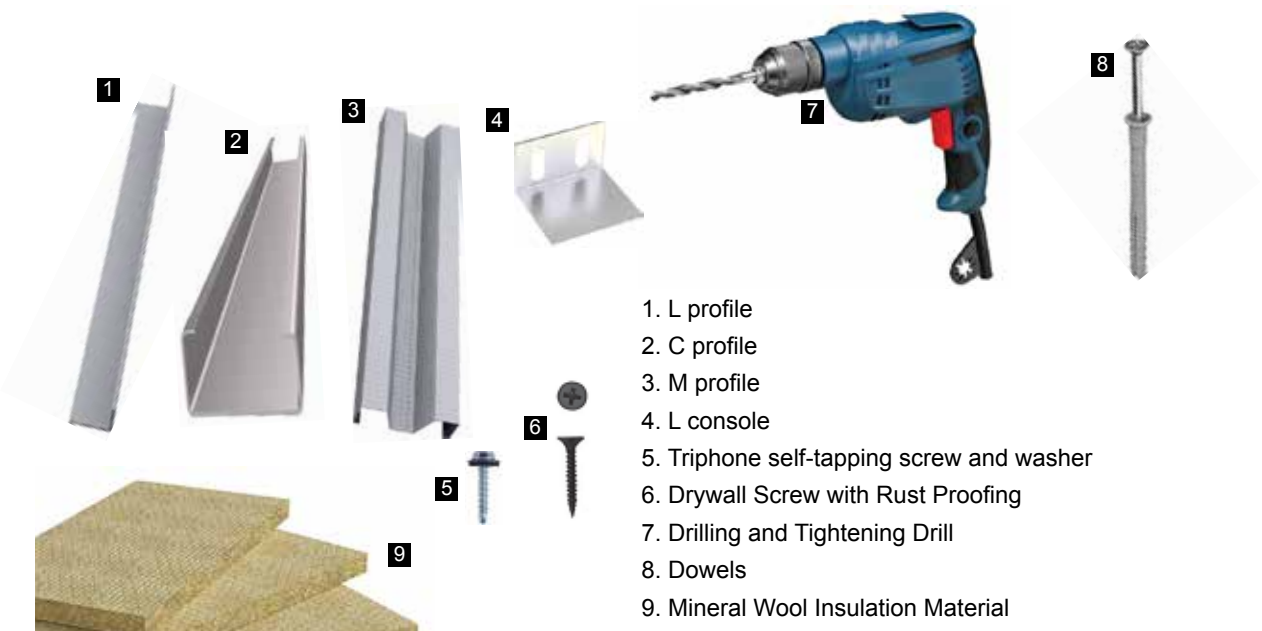

1. L profile
2. C profile
3. M profile
4. L console
5. Triphone self-tapping screw and washer
6. Drywall Screw with Rust Proofing
7. Drilling and Tightening Drill
8. Dowels
9. Mineral Wool Insulation Material

CUTTING PROCESS

Betopan® and tepePAN® panel production lengths have been determined based on their fields of application and purpose. Betopan® and tepePAN® group façade panels are delivered in panels from the factory or cut into strips according to the executed project. However when the design is not clear ahead of time, assembly may require the panels to be cut in custom lengths on the location where the project takes place. It is recommended that in order to provide protection from the dust and pieces that can fly out during beveling and cutting, the precautions suggested in work safety should be taken (mask, gloves, glasses, etc.). Some different methods and tools are used in the cutting process for betopan group products and fibercement group products:

Betopan and Plus Group Products:

The cutting process for the betopan® and betopanplus® group products is done on mobile or fixed cutting benches with hard metal tip or diamond tip saws.

Footnote: Since betopan® group products have layers that are more durable against outside elements it is recommended that the edges of the products be beveled after custom cutting.

Fibercement Group Products:

Circular saws that are produced especially for fibercement should be used for cutting TepePAN® panels.



Easy Cutting Without Dust:

The fibercement group panels can be cut cleanly with special fibercement scissors and blades. This feature enables the panels to be cut in closed areas without dust.



THE APPLICATION STAGES FOR L CONSOLES AND L AND M PROFILES ON EXTERNAL FACADES

The suitable size of L consoles is selected to level the surface of application and use the desired thickness of insulation material.



The position of the L consoles are determined and marked at 1 meter intervals. (May vary according to static calculation)



The places to drill for fixing the L consoles to the wall with dowels are marked.



The L consoles for which the dowel locations have been marked are fixed into place using the right type of dowel.



The desired thickness of insulation material is applied on the fixed L consoles.



The applied insulation material is fixed to the application surface using parachute dowels.



After installing the insulation material on the surface the appropriate length of L profiles are fixed onto the L consoles using the drill to screw in triphone screws.



The thing to be careful of at this stage is that rust proof screws are used. It is important that rust proof screws are used at this stage.



In order to make sure that the L profiles that have been installed do not have curving problems on the surface they should be leveled at certain intervals.



The levelness of the L profiles should be checked throughout the mounting surface.



The M profiles are attached to the surfaces of L profiles, for which the leveling has been checked, using triphone self tapping screws screwed on to the center of the L profiles as shown in the photograph.



The M profiles that are used should be galvanized 20x80x3000 mm size and 0.50-0.55 mm thick. (The M profile dimensions and thickness may vary according to the static calculation).



After the base construction stages are completed, the panels are cut into the dimensions needed when starting the installation of the product.



After the base construction stages are completed, the panels are cut into the dimensions needed when starting the installation of the product.



A diamond tip lateral cutter or diamond tip mobile cutter is used for the betopan® group and circular saws especially produced for fibercement are used for the tepePAN® group.



16

After the cutting process is completed the panels are mounted on the M profiles with rust proof screws.



17

The panels should be screwed onto the M profile wings and during the process of screwing them in, 0.5 mm gaps should be left between the panels to be fixed onto the two wings.



18

While screwing on the lower and upper sections of the panels 2.5 cm of slack should be left from the upper and lower border.

THE PAINTING PROCESS

The panels with cement produced by Tepe Betopan can be used safely in any weather condition without the need of additional protective plaster or layer of coating due to the durability they get from the cement content. In other words, betopan® is already finished material and it only requires painting following the completion of assembly. It saves time on plastering labor and time. The dust and particles on the surface need to be removed before painting. The surface that is going to be painted must be dry and the temperature should be over 5°C.

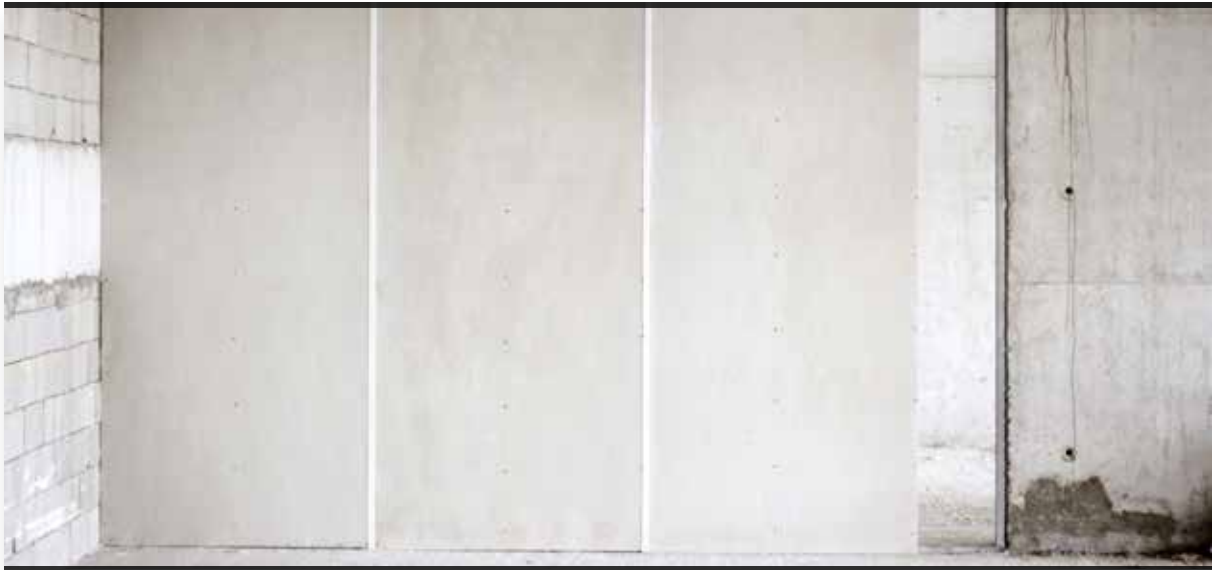

After the accessories and panel mounting is completed, the heads of screws are hidden with acrylic putty and spatulas to prepare the surface for painting. Since excessive putty can lead to cracking a proper amount should be used.



The areas where putty has been applied should be sanded down with fine sandpaper. The accessories and panels can be painted with alkali resistant, acrylic based outdoor façade paint. In order to increase the durability of the paint to outdoor conditions the surface should be cleaned and painted with a single layer of primer.

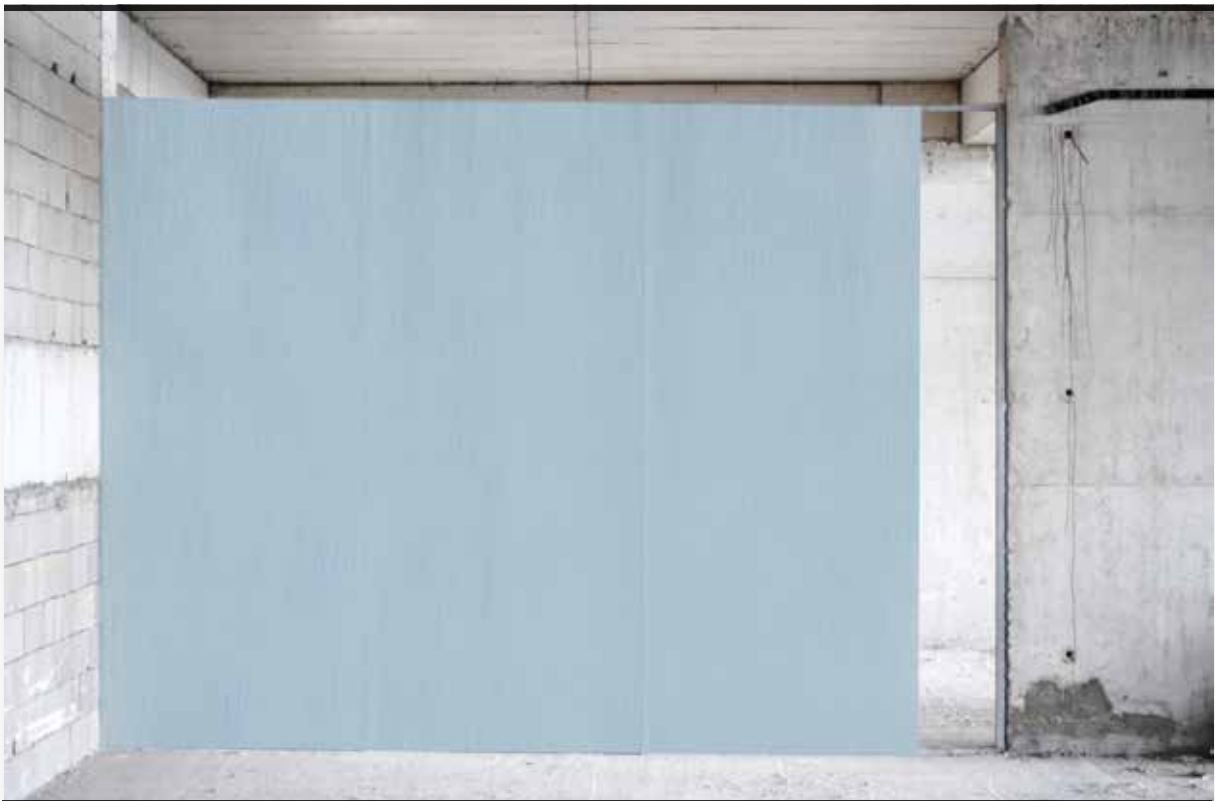

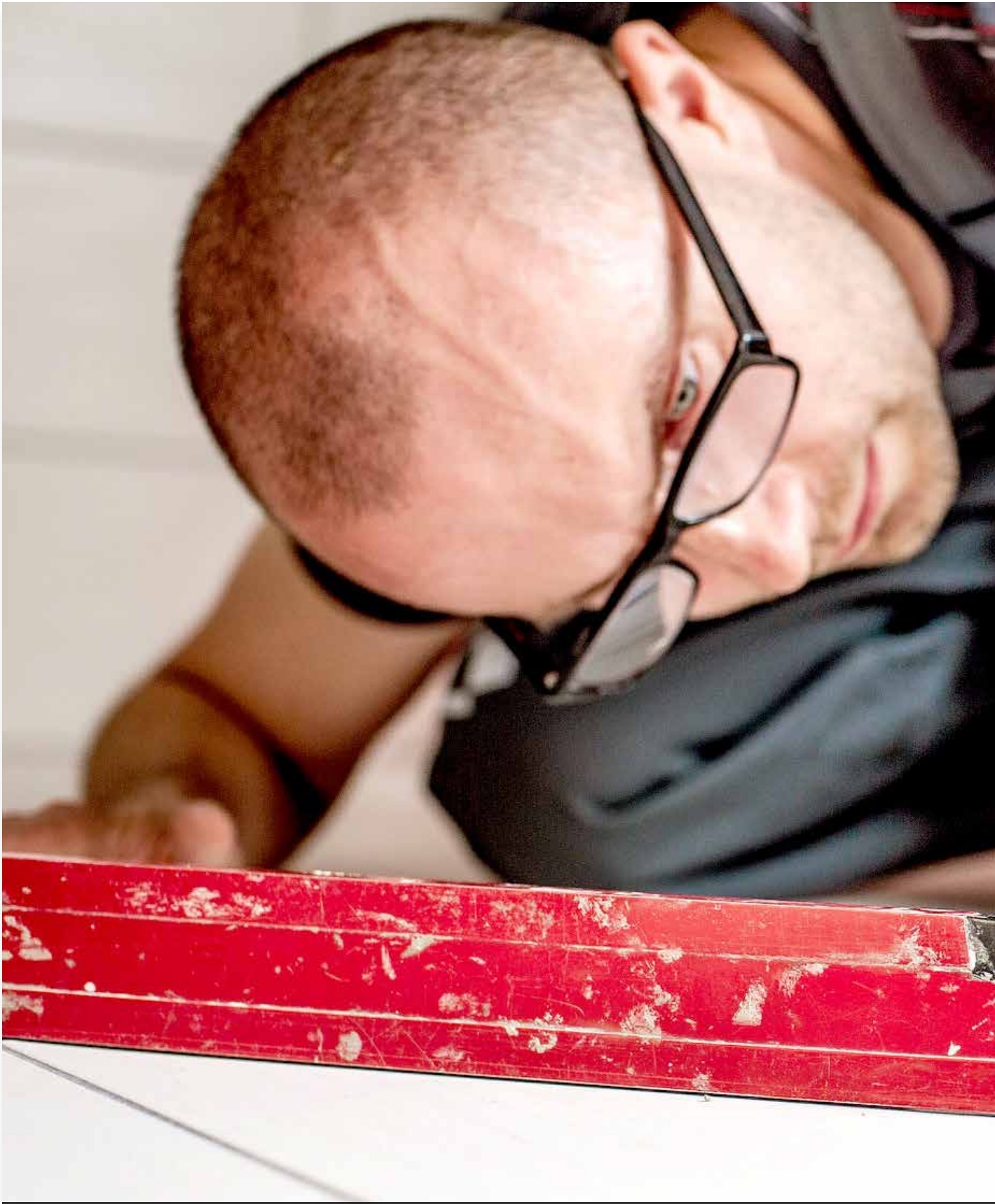



APPLICATION FIELDS

APPLICATION FIELDS

There are different forms of applications for the betopan® and betopanplus® panels that are used frequently in prefabricated homes, containers, steel structures and cabins that may vary by the manufacturer. In this section, the fields of application for betopan® and betopanplus® will be examined under subheadings.

WALL APPLICATIONS

The systems that are used most frequently in prefabricated and similar applications are the sandwich panel systems. In this system, sandwich panels are made with the betopan® or betopanplus® products used for making walls with the insulation materials in between; then these panels are placed into the load bearing steel framework (H, C, U Profiles) of the prefabricated structure. After the application, the primer and the last layer of paint are applied.

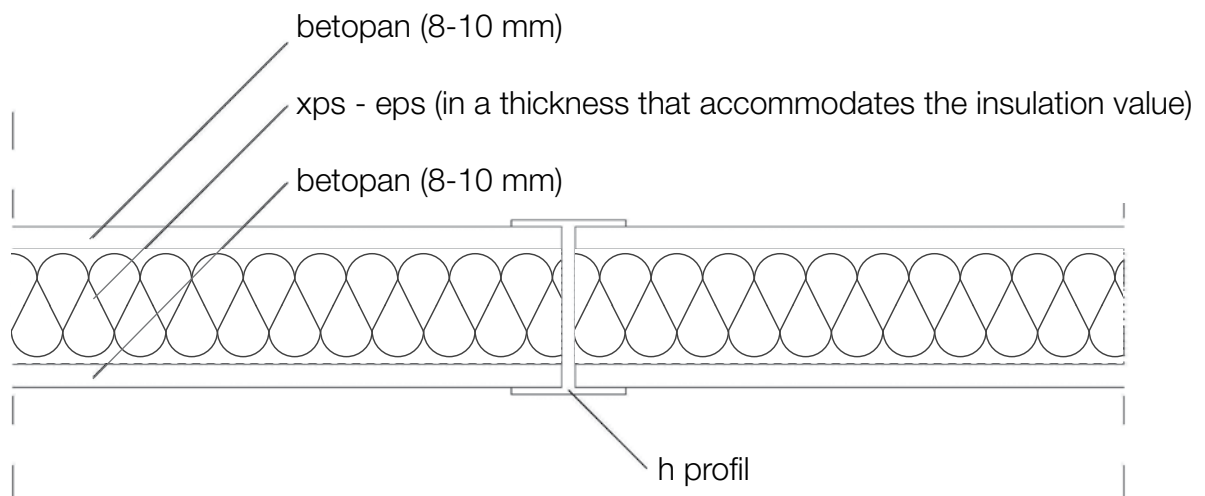

Details for a wall in which sandwich panels and h profiles were used



GROUND APPLICATIONS

Before starting the assembly of the betopan® panels to be used in building the floors in prefabricated, container and similar applications, the steel framework elements that will bear the load on the ground should be laid out at certain intervals (according to the thickness of the betopan® panels that will be placed on the base and the framework gaps) and according to the maximum load they are expected to bear. In order to limit humidity related movement, it is recommended that the length of panels do not exceed 125-150 cm. Later, depending on the preference of the user, the final layer of material is applied (carpet, PVC, parquet, etc.). Under materials like carpet with high permeability, a polyethylene or similar steam equalizer is spread to cover 20cm (40 cm in joints of two betopan®).



MEZANNINE APPLICATIONS

Mezzanine Application in Prefabricated Structures:

Sometimes multilayered applications are encountered in prefabricated and similar applications. In such applications the assembly is continued after the lower layer application is finished by mobilizing the mezzanine load bearers. Again the framework should be built with gaps paying attention to principles like load bearing during the construction of the base.



Inside the framework, the necessary sound, heat and plumbing insulation is finished.



Footnote:

- In order to limit humidity related movement it is recommended that the length of panels do not exceed 125-150 cm in length.
- Depending on the preference of the user, the final layer of material is applied (carpet, PVC, parquet, etc.).
- Under materials like carpet with high permeability, a polyethylene or similar steam equalizer is spread to cover 20 cm (40 cm in joints of two betopan®).
- If wanted the betopan® or betoplus® is applied under the framework.

Mezzanine Application in Reinforced Concrete Structures:



The assembling starts with immobilizing the mezzanine load bearers. The framework should be built with gaps paying attention to principles like load bearing during the construction of the mezzanine.



After the metal sheet covering or coating cover in different thicknesses according to the calculations are placed on this framework, insulation for sound, heat, etc. and plumbing is applied if necessary.



Once the necessary details are completed the betopan® panels in the needed thickness and size (min. 16 mm) are placed and assembly is completed.

Footnote:

- When choosing the load bearing construction gaps and betopan® thickness the below load distribution table should be used.
- There should be bearers under all of the edges of betopan® being used.
- In order to limit humidity related movement it is recommended that the length of panels do not exceed 125-150 cm.
- Depending on the preference of the user, the final layer of material is applied (carpet, PVC, parquet, etc.).
- Under materials like carpet with high permeability, a polyethylene or similar steam equalizer is spread to cover 20cm (40 cm in joints of two betopan).

betopan® LOAD BEARING CHART



From center to center	Nominal thickness	Bearing Strength
Support Gap (mm)	(mm)	(kg/m ²)
417	16	500
417	18	644
417	24	1146
417	30	1833
467	16	387
467	18	500
467	24	887
467	30	1410
500	16	340
500	18	437
500	24	764
500	30	1196
600	16	239
600	18	306
600	24	550
600	30	859
625	16	220
625	18	284
625	24	500
625	30	809

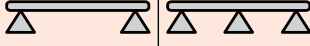

From center to center	Nominal thickness	1 Gap	2 Gaps
Support Gap (mm)	(mm)	Bearing Strength	Bearing Strength
417	16	474	465
417	18	611	598
417	24	1100	1066
417	30	1719	1698
467	16	387	369
467	18	509	474
467	24	887	844
467	30	1440	1341
500	16	348	320
500	18	451	411
500	24	809	731
500	30	1250	1165
600	16	262	226
600	18	335	291
600	24	598	518
600	30	948	826
625	16	229	210
625	18	320	270
625	24	561	482
625	30	887	762

Chart 6: > 3 Load Bearing Values for Panels with Gaps

Chart 7: Load Bearing Values for Panels with 1 or 2 Gaps

The material safety coefficient and the irregularity coefficients that may result from loading and final load bearing capacities calculated taking into account critical deflection according to TS 500 (L/360). Means the plaque weight and mobile load total value. The TS 498 chart 7 values according to TS 500 should be compared with the load bearing strength in the table after being multiplied with the 1.6 safety coefficient. For example the 2kN/m² calculated value provided for home and office flooring in row 2 of the chart is compared with the 314 kg/m² load bearing strength obtained by multiplying with the 1.6 safety coefficient.

SUSPENDED CEILING APPLICATION

With the proper material selection a steel load bearing framework is formed for the suspended ceiling. When forming this framework at least a 0.5 in one thousand of the total length of panel on each side should be left between the panels and the profiles should be selected taking into account that they will be applied at least 2.5 cm from the inside.

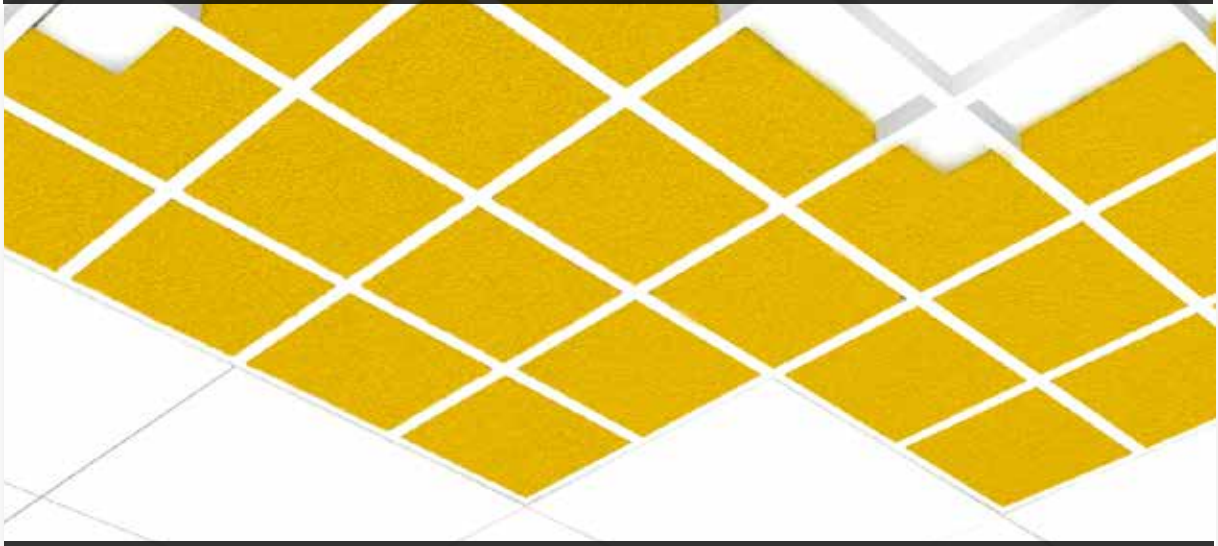

Betopan® products are mounted as 8 mm and in modular cuts (maximum 50x50 cm or 60x60cm).



The screw heads are covered with paste and paint is applied.

Footnote:

- In order to limit movement, it is recommended that each side of the panels be painted with at least two coats (300 gr/m²) of polyurethane based paint.
- If the centers of the assembled panels are painted with the paint used on the bottom of betopans® a different color will not be perceived on the grout seen after assembly, small workmanship errors will not be noticeable.

ELEVATED FLOOR APPLICATION

With the help of steel feet and belts the construction of the elevated floor is formed.

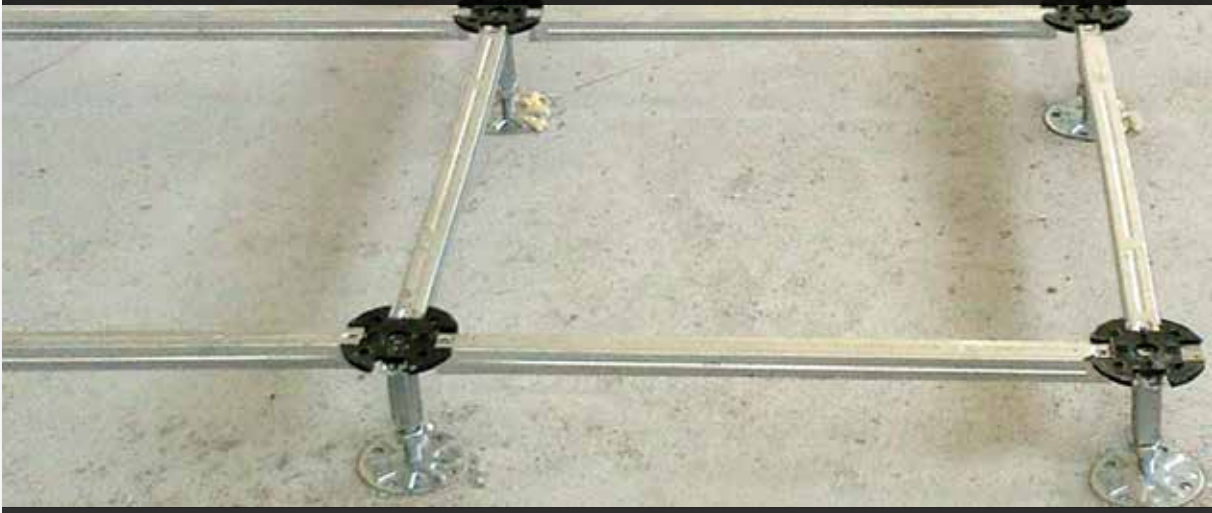

The betopan® (600x600mm) in 28 and 30 mm thickness is placed on the construction with PVC tape around the edges.



Top and bottom coating material according to the end user preference is applied on the product to make it ready for use.



ROOF APPLICATION

The products that provide advantages on issues like adverse effects from water, difficulty in assembling, multiple joints, etc. in roof systems are bolted in towards the beams. The secondary water insulation materials are applied on the betopan® then the last coat is applied and the panels are mounted. The roof covering needs to be bolted to the betopan® and no nails should be used. When betopan® is being applied on beams, care should be taken to make sure that each edge comes on a bearer.

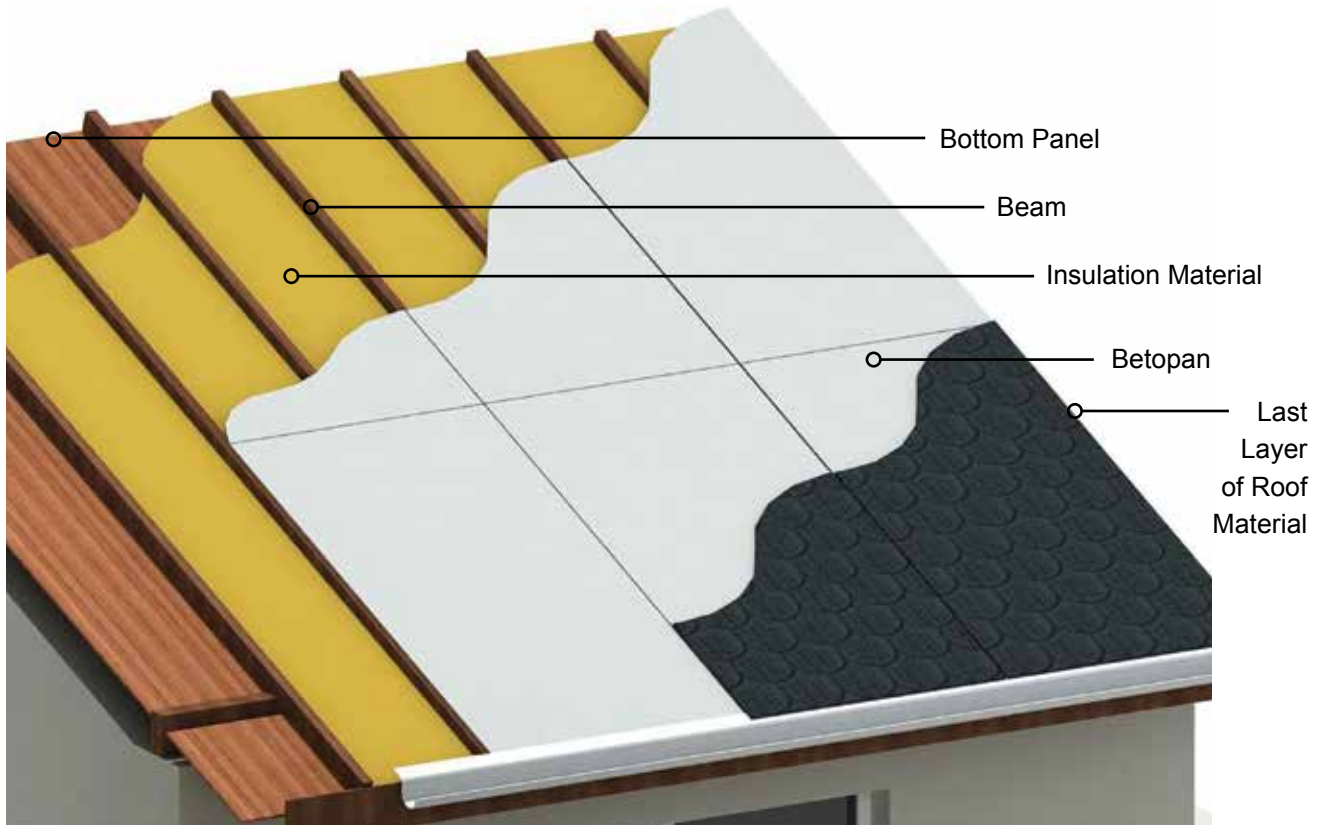

WET AREA APPLICATION

Betopan® or betopanplus® panels used in making walls are formed into sandwich panels with the insulation materials and assembled. Steel profiles are used as bearers in the assembly. The joints can be covered with covering profiles applied later.



When applying ceramic products to wet area walls covered with betopan® or betopanplus® you must be careful to use polyurethane mastic. When adhering the ceramic products on the joints the tile should not be adhered to two tiles at once but to the betopan® panel that covers more area. The joints should not be offset, the joint gap should be 5 mm, the vertical joints close to the panel joint spots should be coated with polyurethane mastic. The same color joint mortar can be applied to the other joints.



UNDER EAVE, EAVE FACE, BALCONY AND TERRACE CEILINGS

On eaves, balconies and terraces which are the parts of buildings most exposed to outdoor factors and therefore the weakest areas generally sustain cracks and chipping from time to time. The use of betopanplus® panels under and on the face of eaves for the purpose of preventing this type of chipping and bad appearance and to obtain a more aesthetic look is common. The betopanplus® panels are applied by bolting them at the guide holes drilled before the M profiles.



A point of caution is that the panels are used in primed form and later painted with the last coat of paint. Depending on the preference, betopan® with different patterns can also be used. Betopan® panels provide a more durable surface compared to wood on the underside and front face of eaves.



ELEVATOR SHAFTS

The walls of elevator shafts must be built with fire resistant material from base to ceiling. Since these applications are generally built with steel construction, the walls must be coated with fire resistant panels. In these types of areas betopanplus® is usually the preferred material.

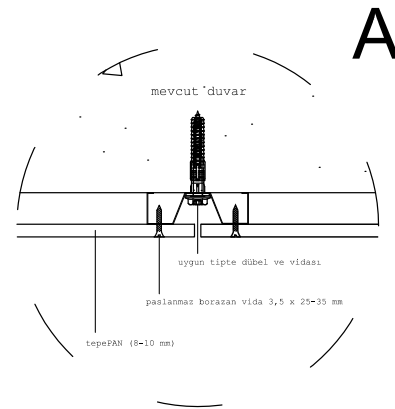
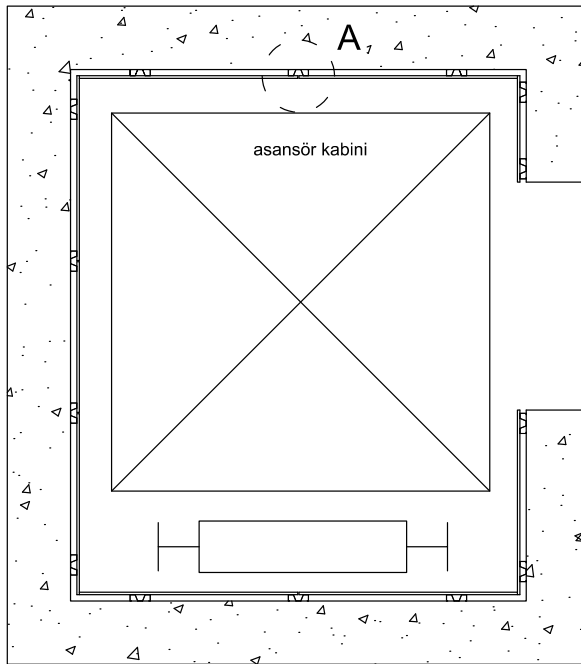

FIRE DOORS

Especially in public areas (like shopping centers, cinemas, schools, gyms, etc.) one of the points of caution in terms of fire safety is fire emergency doors. The maximum resistance to fire is demanded for these doors. Although there is not a lot of use in this field yet in Turkey, doors with both sides covered with betopan® (with air gaps and insulation material in between) provide very superior fire resistance.

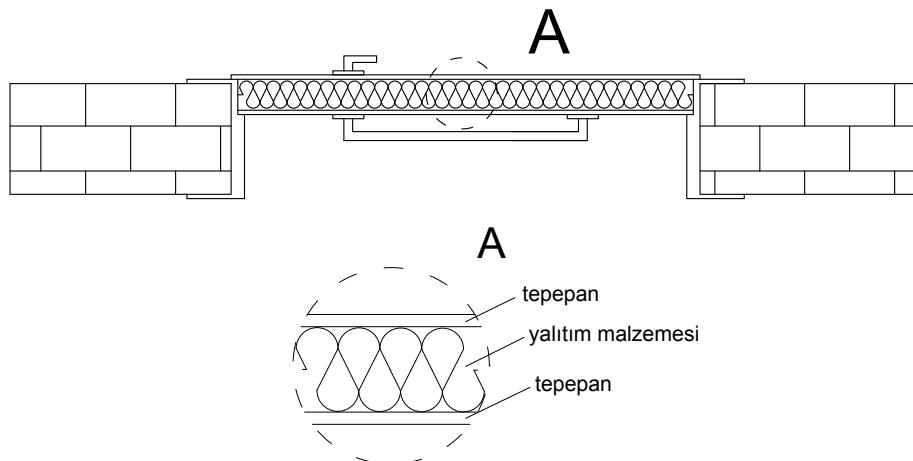



WALL SYSTEMS



APPLICATION TYPE AND PRINCIPLES

Tepe Betopan panels with cement on the internal section walls of buildings:

- ✓ In heavily used areas where impact resistance is sought ,
- ✓ In areas where fire resistance is sought,
- ✓ In areas where the risk of water, damp or mold is high,
- ✓ In areas where a high level of sound and heat insulation is necessary,

These panels enable walls to be built quickly.

The panels, which are bolted onto the bearer profiles formed according to the project, can be painted directly without plastering or can be used to form the base for coating applications like ceramics and wall paper.



APPLICATION WITH OMEGA PROFILES

Recommended products:

External Façade: 10/12 mm thickness betopan®

Internal Façade: 8/10 mm thickness betopan®

Omega profiles are seen at the vertical joints.

This application is done by fixing the bearing wall profiles (box profile, wall C) vertically so that they fall on the edges and centers of the complete panels used lengthwise; then the panels are bolted to the profiles that fall on their center. The panel edges are clamped under the wings of the omega profiles bolted to the edges.

After the omega caps are placed over the screw grooves of the omega profiles the screw places are filled in with polyester or acrylic paste and sanded. Then the surface is painted to complete the application. Insulation material is used between the profiles according to the need of insulation.



STANDARD JOINTED APPLICATION

Recommended products:

External Façade: 10/12 mm thickness tepePAN® - betopan®

Internal Façade: 8/10 mm thickness tepePAN® - betopan®

Instead of profiles on the surface vertical joints are seen.

This application is done by fixing the bearing wall profiles (box profile, wall C), for which the cut and dimensions have been determined according to the project, vertically so that they fall on the edges and centers of the complete panels used lengthwise; then the panels are bolted directly to the profiles.

In this type of application joints of 5mm are left between the panels. After polyurethane mastic is applied to the joints for aesthetic appearance the screw places are filled in with polyester or acrylic paste and sanded. Then the surface is painted to complete the application.

DECORATIVE JOINTED (WITH GROOVED UNION) APPLICATION

Recommended products:

10/12 mm thickness tepePAN® - betopan®

Instead of profiles on the surface vertical decorative joints are seen.

This application is done by fixing the bearing wall profiles (box profile, wall C), for which the cut and dimensions have been determined according to the project executed, vertically so that they fall on the edges and centers of the complete panels used lengthwise; then the panels are bolted directly to the profiles.

In this type of application, when the panels are placed side by side, joints of 5-25 mm are formed between the panels depending on the groove detail. The screw places are filled in with polyester or acrylic paste and sanded. Then the surface is painted to complete the application. Insulation material is used between the profiles according to insulation need.

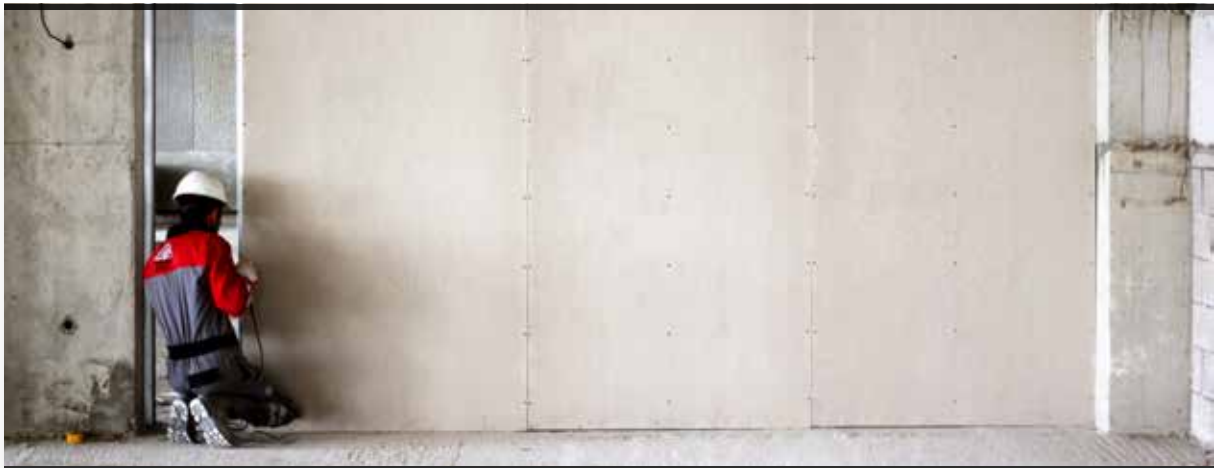



The placement of the surface on which the dividing wall is to be applied is determined.



The surface on which the U profiles are to be applied is determined using leveling line or a lateral vertical laser level .



Determining the surface onto which the U profiles are to be applied is determined using leveling line.



U-Profiles is cut and prepared appropriately in accordance with the divided wall surface



The U profiles for which the measurement and alignment has been determined are placed according to the alignment .





When the length is not sufficient the necessary measure and number of U profiles can be added.



In the profile that is overlapped, the overlap part should be about 5 cm for bolting.



The profiles that are placed inside one another are checked one last time and aligned.



The dowel positions of the U profiles that have been aligned and placed are determined.



The dowel positions of the U profiles that have been aligned and placed are determined.





The dowels that will fix the U profiles can be 8x80 mm, 8x100 mm and 8x120 mm as needed.



The dowels are placed in the predetermined positions with a hammer.



The dowels that have been placed in the predetermined positions with a hammer are fixed to the ground with a drill.



The U profile that is to be fixed to the wall surface is placed inside the U profile fixed to the floor.



Before fixing the wall U profile the dowel places are determined and fitted into place.



The fitted dowels are fixed to the wall surface using a drill.



22

**BOTTOM CONSTRUCTION SYSTEM**

After fixing the wall U profile measurements are taken and marking made for placement of the H profiles.

23

**BOTTOM CONSTRUCTION SYSTEM**

The H profiles are placed in the floor U profiles at max. 62.5 cm intervals and fixed to the floor.

24

**BOTTOM CONSTRUCTION SYSTEM**



The H profiles are fixed to the top profiles and the level is checked.



After fixing the floor U, wall U and H profiles the measured panels are placed on the construction surface.

28



JOINTED (GROOVED UNION)

29



JOINTED (GROOVED UNION)

30



JOINTED (GROOVED UNION)



The screw locations are determined and marked on the panels.



Rust proof screws should be used.



34



35



The screws should be driven in 20-30 mm from the edge of the panels into the profiles under the panels.

36



The gaps between the screws should not be more than 30 cm.



The screws are driven vertically into the surface and countersinking should be applied to sink the screws into the panels.



After the front surface of the dividing wall is complete, the necessary wiring etc. should be passed between the H profiles and prepared for insulation.

40

**WITH OMEGA PROFILES**

After placing the fixture cables, the insulation material is packed between the H profiles.

41

**WITH OMEGA PROFILES**

The mineral wool is carefully applied on the whole surface and the surface is prepared for mounting the panels.

42

**WITH OMEGA PROFILES**



After finishing the fixture and mineral wool application, the panels are placed on the prepared surface.



The leveling of the placed panels is checked.





The Omega profiles are fixed to the H profiles and the panels are packed under the omega wings.



The mounting of the omega profiles is done with special 3.5x25 or 3.5x35mm rust proof screws.

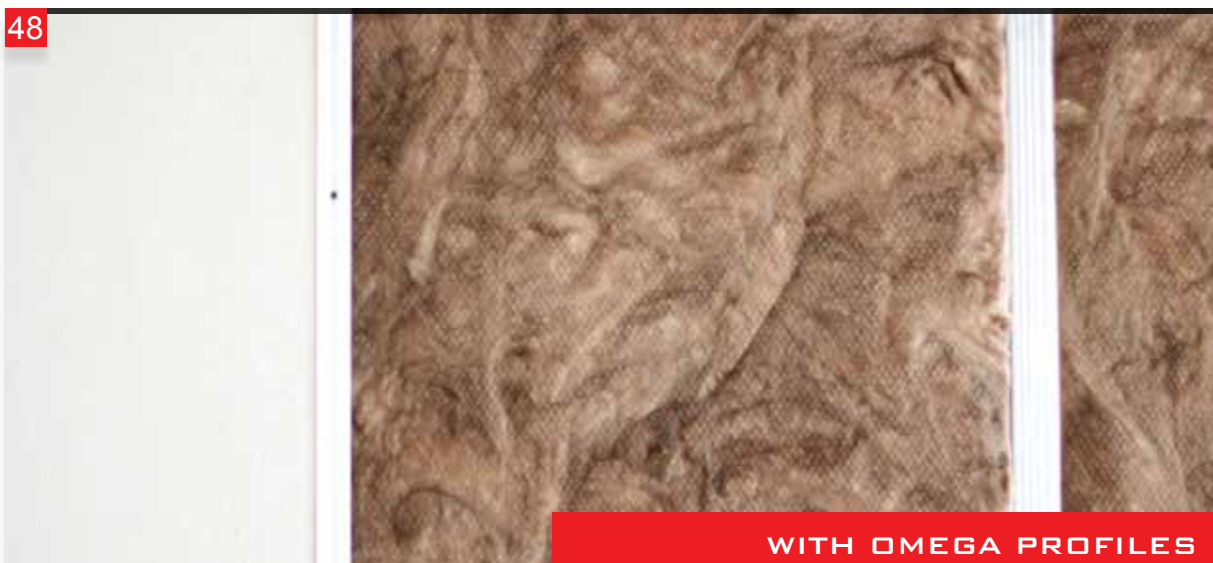



A panel is screwed to the H profile at max. 30 cm from the middle axis between the omega profiles. (the screws should be driven in 20-30 mm above the floor).



The other panels are prepared to be placed on the omega profile.



The omega profile between the aligned panels is mounted so the panels are under the profile wings.

52



53



54



The omega profile that has been mounted is connected to the H profile with a drywall screw from the joint slots.



The screws should be driven in vertically to the joint slots.



The joint places of the omega profiles for which the screwing process is completed, are covered using profile piping.

58



WITH OMEGA PROFILES

59



WITH OMEGA PROFILES

60



WITH OMEGA PROFILES

On outside surfaces on the place where the panels and omega profiles join, polyurethane mastic is applied for waterproofing. The screw places are filled with acrylic paste and sanded.



EXTERNAL FAÇADE BUILDING PANELS



BETOPANPLUS STRONGER, MORE DURABLE

Betopanplus® is a non-patterned panel that is the combination of particle board, cement and some harmless chemical additives with both surfaces shielded with natural minerals. This combination has created a panel with low movement caused by the relative humidity and outside factors, durability as strong as good quality concrete and ability to apply any paint that can be applied to concrete surfaces.

- ✓ High fire class (A2 Fire Class),
- ✓ Damp, moisture and water resistance,
- ✓ Low capillarity,
- ✓ Resistance to movement caused by humidity,
- ✓ Insulation against airborne noise,
- ✓ Endurance to biological waste,
- ✓ Endurance to impact,
- ✓ Endurance to insects, termites and fungus,
- ✓ Endurance to shore conditions,
- ✓ Endurance to sun, frost and other severe weather conditions,
- ✓ Easy processability, light and simple assembly
- ✓ Does not contribute to fire,
- ✓ Does not emit toxic gas in fire,
- ✓ Very low water absorption and swelling in water,
- ✓ Low maintenance,
- ✓ Able to be repainted and reused with just a paint over,
- ✓ More durable against different weather conditions
- ✓ Hold paint longer,
- ✓ Decorative texture can be added to the surface of these building and façade panels.

MEASUREMENTS

Thickness: 10/12 mm

Width: 1250 mm

Length: 3000 mm

Special Size: Can be custom cut for special production between 14-30 mm



FIELDS OF USE

- ✓ On outer façade cladding,
- ✓ On interior of areas like shops, galleries, store windows and studios (for decoration),
- ✓ As a background panel in advertisements, boards
- ✓ In the building of site fences,
- ✓ In electrical transformers,
- ✓ Under ceramic and plaster (as background panels),
- ✓ In CNC incorporating patterns (for decoration),
- ✓ In fire doors and escape corridors,
- ✓ In building fire prevention walls,
- ✓ In the base of suspended floors as a load bearing floor and under flooring,
- ✓ As an under panel for a roof cover,
- ✓ In prefabricated buildings,
- ✓ As a suspended ceiling panel,
- ✓ As impact protection panels on applied surfaces.
- ✓ As elevated flooring panels,
- ✓ Under balconies and interval sections,
- ✓ On the walls of elevator shafts and fire escape walls,
- ✓ On the walls and floors of areas where work is done with water,
- ✓ In animal shelter floors and walls,
- ✓ In greenhouses,
- ✓ In the fire insulation of steel building elements,
- ✓ In the surface coatings of steel building elements,
- ✓ Construction of pressed wall panels with insulation,
- ✓ Under building eaves and eave panels,
- ✓ For decoration in elevator frames and building entries,
- ✓ Can be used as frame accessories on door and window frames



BETOPANPLUS

TECHNICAL SPECIFICATIONS



Technical Specifications	Applicable Standart	Betopan Brand, Class 1, Non-Sanded, Cement-Bonded Particle Boards (Ts En 633, Ts En 634-1, Ts En 634-2)	Plus Group, Class 1, Non-Sanded, Cement-Bonded Particle Boards With Particle Free Surfaces (Ts En 633, Ts En 634-1, Ts En 634-2)
Unit Volume Weight	TS EN 634-2, TS EN 323	1300 ± 50 kg / m ³	1450 ± 75 kg / m ³
Bending Strength	TS EN 634-2, TS EN 310	≥ 9 N/mm ²	≥ 9 N/mm ²
Bending Elasticity Modules	TS EN 634-2, TS EN 310	≥ 4500 N/mm ² (Class 1)	≥ 4500 N/mm ² (Class 1)
Tensile Strength: Vertical to the surface Vertical to the surface in Moist Environment after C Test Parallel to the surface	TS EN 634-2, TS EN 319 TS EN 634-2, TS EN 321, TS EN 319 TS EN 789	≥ 0,5 N/mm ² ≥ 0,3 N/mm ² ≥ 4 N/mm ²	≥ 0,5 N/mm ² ≥ 0,3 N/mm ²
Pressure Resistance	TS EN 789	≥ 15 N/mm ²	
Swelling in Thickness: After immersion in water for 24 hours In moist environment after cyclic test	TS EN 634-2, TS EN 317 TS EN 634-2, TS EN 321, TS EN 317	≤ % 1,5 ≤ % 1,5	≤ % 1,5 ≤ % 1,5
Screw Holding Strength: At 10 mm thickness At 18 mm thickness	TS EN 1380 TS EN 1380	168 N for 4.2 x 65 mm screw 300 N for 4.2 x 65 mm screw	
Moisture Content	TS EN 634-1, TS EN 322	% 9 ± 3	% 9 ± 3
Wood Destroying Pests	TS EN 335-3	"Risk of being affected by wood destroying pests in the whole danger class is negligible"	"Risk of being affected by wood destroying pests in the whole danger class is negligible"
Formaldehyde Release		Substances with formaldehyde content are not used in production.	Substances with formaldehyde content are not used in production.
Asbestos		Substances with asbestos content are not used in production	Substances with asbestos content are not used in production
Tolerances Thickness Lenght and width Edge Smoothness Corner Verticality	TS EN 634-1, TS EN 324-1 TS EN 634-1, TS EN 324-1 TS EN 634-1 TS EN 634-1	08-10 mm ± 0,7 mm 12-14 mm ± 1,0 mm 16-18 mm ± 1,2 mm >18 ± 1,5 mm Length: ± 5 mm En: ± 5 mm ≤1,5mm / m ≤2mm / m	08-10 mm ± 0,7 mm 12-14 mm ± 1,0 mm 16-18 mm ± 1,2 mm >18 ± 1,5 mm Length: ± 5 mm En: ± 5 mm ≤1,5mm / m ≤2mm / m
Standart Dimensions and Weights		Thickness (mm) : 08,10,12,14,16,18,20,24,30 Weight (kg/m ²) :10,13,15,18,20,23,26,31,39 Width (mm): 1250 Lenght (mm): 2500,2800,3000	Thickness (mm) : 08,10,12,14,16,18 Weight (kg/m ²) : 12,15,18,21,24,27 Width (mm): 1250 Lenght (mm): 2500,2800,3000
Heat Conduction (λ) (at 8-12 mm thickness at 10°C) (at 14-18 mm thickness at 10°C)	TS EN 12664 TS EN 12664	0,15-0,16 W/mK 0,15-0,16 W/mK	0,19 W/mK 0,19 W/mK
Heat expansion coefficient (µm/mK): for 10 mm thickness for 18 mm thickness	DIN 51045 DIN 51045	11.5 11.6	
Fire Resistance (European Class)	DIN EN 13501-1, DIN EN 13823, DIN EN ISO 11925-2	Fire: B, Smoke: s1 Fall of particles of burning drips: d0	10 mm & 8mm1; Fire: A2, Smoke: s1, Fall of particles or burning drips: d0
Fire Resistance (UK Class)	Building Regulation, Document B2, Chapter 6	"Class 0" European Class is equivalent to B-s3, d2. (There is no limit for smoke in s3, and no limit for burnt and dropping pieces in d2)	
Fire Resistance Duration	TS 1263 (DIN 4102-2)	Thickness (mm) : 08 , 10 , 12 , 14 , 16 , 18 Time (minutes) : 31 , 32 , 34 , 35 , 37 , 39	
Tests on other thicknesses are proceeding Linear stability depending on relative humidty (RH) (mm/m) In shadow: at 8-12 mm thickness at 14-18 mm thickness	TS EN 318 TS EN 318	-1,0 (%65---> %35 RH) +0,4 (%65---> %85 RH) -1,4 (%65---> %35 RH) +0,3 (%65---> %85 RH)	
In the sun: 12 mm boards conditioned at 85% ±% 5RH and 20 ± ±2 °C and both surfaces painted (300g/m ²). In Ankara, on sothern facade, after 1 year, at summer end with: Sayarlak brand (Hemel) Amphisilan brand (Filli Boya)		-2,3 -2,5	-1.5 -1.7
Sound transmission loss (R)	TS EN 13986	29 dB at 10 mm thickness 32 dB at 18 mm thickness	31 dB at 12 mm thickness 33 dB at 12 mm thickness
Sound Absorption: 250 Hz - 500 Hz arası 1000 Hz - 2000 Hz arası	TS EN 13986	0.10 0.30	
pH		11-13	
Water Vapor Transmission (µ): At 10 mm thickness At 18 mm thickness	TS EN 13986 TS EN 13986	Dry cup=50 Wet cup=30 Dry cup=50 Wet cup=30	

Yalipan®, which was produced with the warmth that wood adds to facades in mind, has been created by adding wood texture to the most superior features of the plus group. This has enabled a product that does not rot like wood, not get infested and does not require constant maintenance but provides the appearance of natural wood to emerge.

MEASUREMENTS

Thickness: 10/12 mm

Width: 1250 mm

Length: 3000 mm

Special Size: Can be custom cut for special production between 14-30 mm

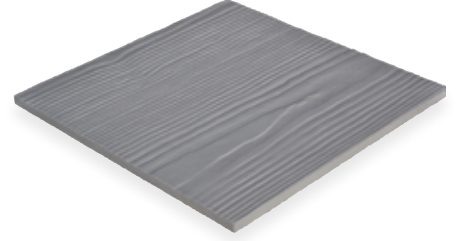

Produced with a homogenous texture similar to stone for use in buildings, Taşonit®, an alternative to natural stone which can add weight to surfaces and fall off over time, has been produced with the superior features of the plus group with a stone appearance.

MEASUREMENTS

Thickness: 12 mm

Width: 1250 mm

Length: 3000 mm

Special Size: Can be custom cut for special production between 14-30 mm

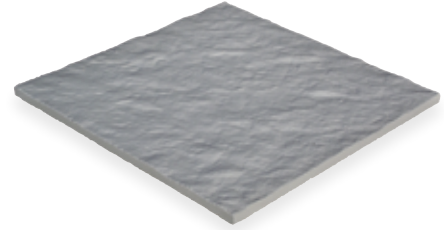

Monolin®, a texture product that joined the plus group, is a decorative patterned outer façade panel produced for daring designs that attract attention at first sight with a radical texture. This panel has been created by Tepe Betopan for designers who want to achieve distinct looks with a linear structure.

MEASUREMENTS

Thickness: 12 mm

Width: 1250 mm

Length: 3000 mm

Special Size: Can be custom cut for special production between 14-30 mm

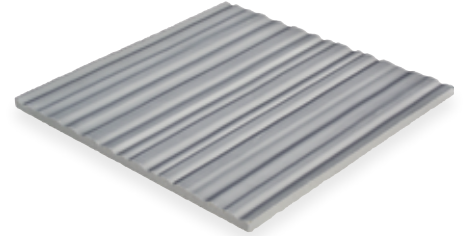

Frapan®, one of the most popular products of the plus group is a decorative patterned outer façade panel produce especially for designs that reflect a distinction with their texture. This type of panel has been created by Tepe Betopan for designers who want to achieve distinct looks with a different structure.

MEASUREMENTS

Thickness: 12 mm

Width: 1250 mm

Length: 2500/2800/3000 mm

Special Size: Can be custom cut for special production between 14-30 mm

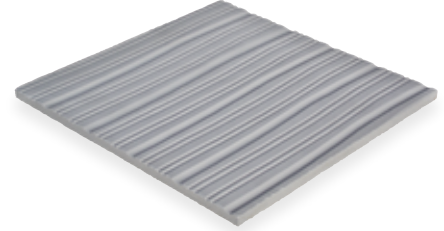

Fugalin®, one of the products of the plus group, is a grooved outer façade panel produced especially for linear, simple and stylish designs. This panel has been created by Tepe Betopan for designers who want to achieve distinct looks with a grooved structure.

MEASUREMENTS

Thickness: 12 mm

Width: 1250 mm

Length: 3000 mm

Special Size: Can be custom cut for special production between 14-30 mm

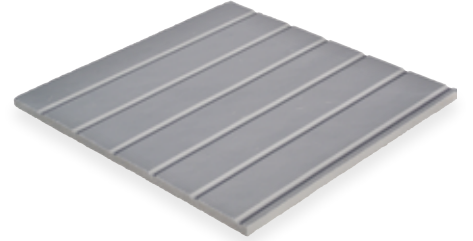

Tuğpan®, one of the latest products to join the plus group, is an outer façade panel with deep texture differences and a cut stone design. This panel has been created by Tepe Betopan for designers who want to achieve distinct looks with stone pattern structure.

MEASUREMENTS

Thickness: 12 mm

Width: 1250 mm

Length: 3000 mm

Special Size: Can be custom cut for special production between 14-30 mm

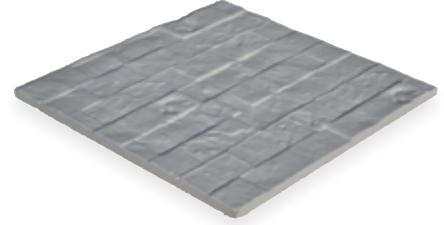

Tuğlapan®, one of the plus group products, is an outer façade panel with offset brick design. This type of panel has been created by Tepe Betopan for designers who want to achieve distinct looks with brick-like appearance.

MEASUREMENTS

Thickness: 12 mm

Width: 1250 mm

Length: 3000 mm

Special Size: Can be custom cut for special production between 14-30 mm





ACCESORIES

Tepe Betopan® provides the materials it produces and sells with detailing solutions. In this context, the company also produces the façade accessory products for joint and finishing touches.

Tepe Betopan® Façade Accessories are also cement based like the panels. Outer corners, internal corners, frames, lento and lath are produced in the accessories factory and therefore do not have the angular defects that can occur in manufacturing on site. The accessories arrive at the site with the mitre joints connected at the factory in 3 meter profiles.

Tepe Betopan® Façade Accessories are in internal corner, external corner, frame, lento and lathe profiles and floor molding form and are produced in different sizes and designs to adapt to design preferences.

Texture Options:

- ✓ Plain (no pattern)
- ✓ Wood texture
- ✓ Stone texture
- ✓ Decorative cross section

Production Thickness:

- ✓ 16 mm ve 30 mm



*The main feature that distinguishes lento from frame profiles is the droplet detail in the lento.

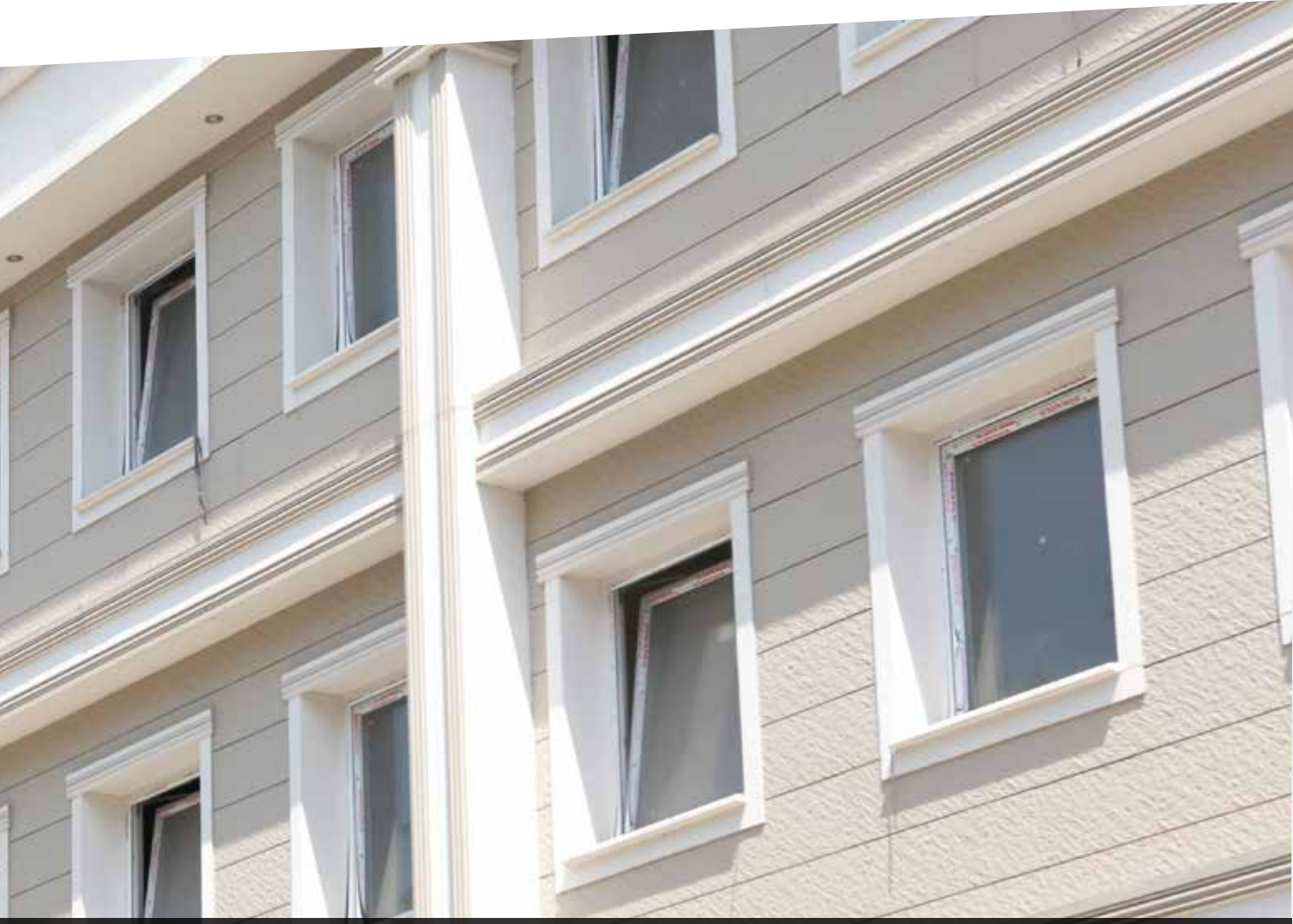
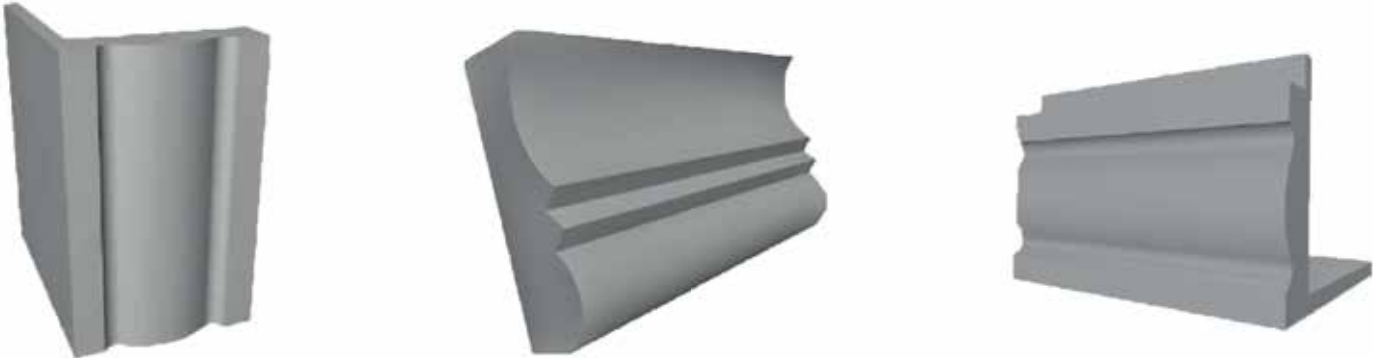

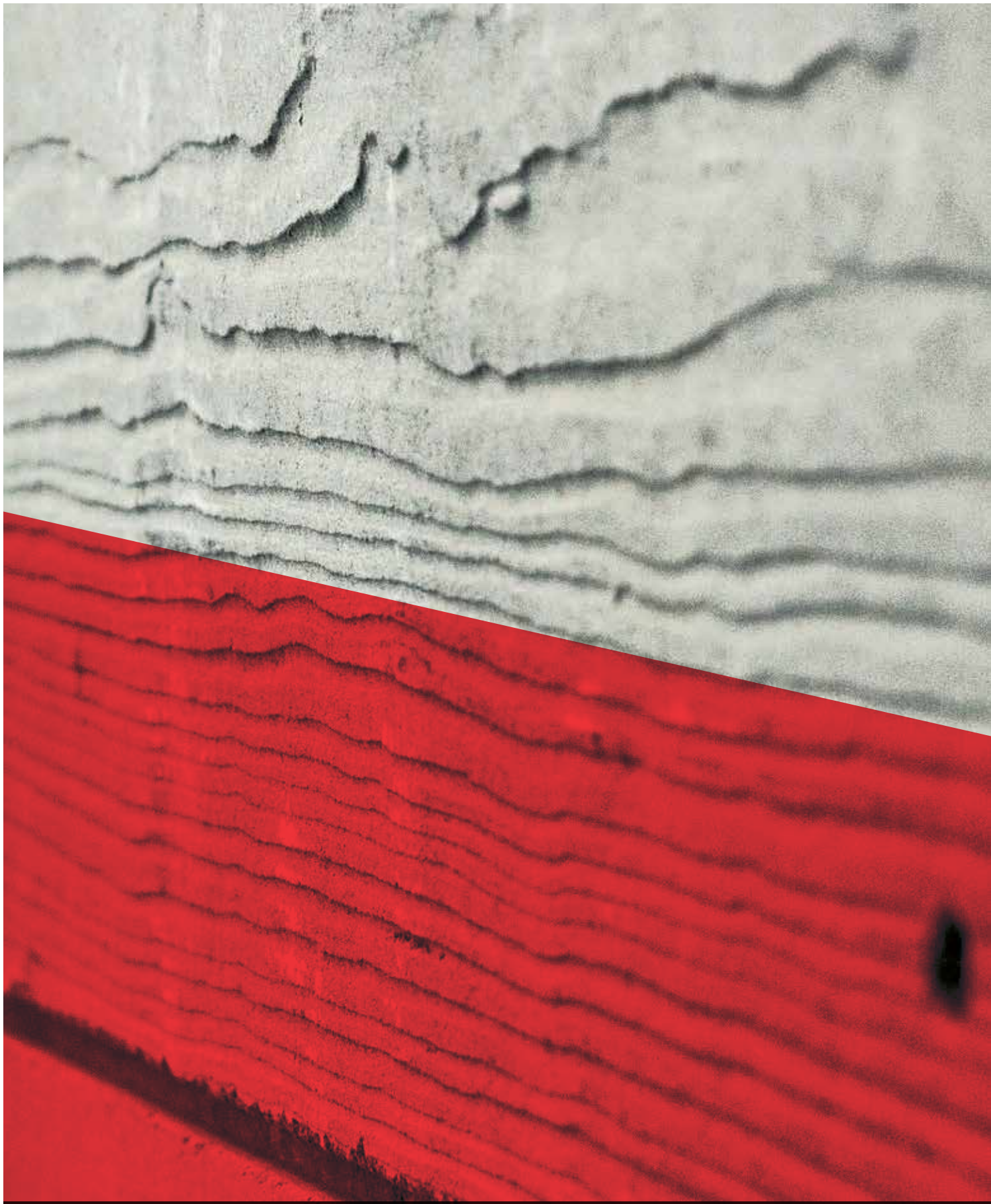



APPLICATION TYPES

GROOVED APPLICATION

This is the commonly-used application method for lateral joints and wood patterned under eave coverings of panels in façade coatings.

Grooves are opened on the long sides of 3 meter strips cut from the whole plates. This is done in the factory setting just like the sizing. When these strips are applied in rows during assembly a decorative joint is created that can be adjusted to 5-25 mm at the joints. This joint will prevent water from getting in. The width of the joint should be notified to the factory in advance. The production is done in a way that will ensure the desired joint width.

Standard Measurements:

- 10 x 175 x 3000 mm
- 10 x 205 x 3000 mm
- 10 x 310 x 3000 mm
- 10 x 410 x 3000 mm
- 10 x 623 x 3000 mm
- 12 x 175 x 3000 mm
- 12 x 205 x 3000 mm
- 12 x 410 x 3000 mm
- 12 x 623 x 3000 mm
- 12 x 310 x 3000 mm

**10 x 1250 x 3000 mm and 12 x 1250 x 3000 mm standard sizes are cut with the least wastage at the workshop.



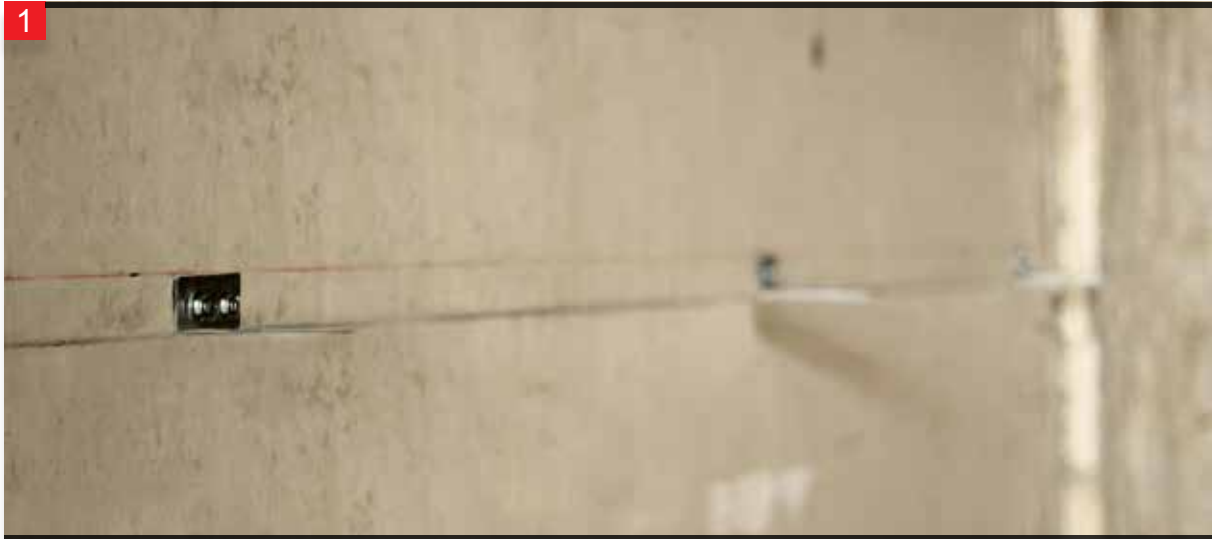

1 The curve of the application surface is determined and suitable L consoles to which the L profiles are to be connected are attached.



2 The necessary amount of stone wool is applied to the wall surface on the fixed L consoles.



3 After fixing the stone wool on the wall surface the L profiles are attached to the L console with triphane bolts.



After the L profiles are fixed to the L consoles the M profiles, to which the panels are to be fixed, are attached to the L profiles.



The panels are screwed onto the surface for which the bottom construction has been completed, with anti rust screws.



The subsequent panels are aligned so that the grooved surfaces sit into each other.



The aligned panels are screwed onto the M profile with drywall screws.



The screws are applied for each M profile and steps 5 through 8 are repeated for all the panels.



FLUTED APPLICATION

This application method is preferred for designs in which a strong fluted perception is desired to be dominant in multi-storey buildings or wide surfaces.

If the preference is for the lateral fluting intervals between the panels to be more than 25 mm or for the fluting to be more prominent, separate fluting strips are used. In this application type the fluting strip is attached between two panels and on the back of two panels overlapping 2,5 cm. The panel in front and the fluting strip in back are screwed onto the M profile together.

Standard Measurements:

- 10 x 310 x 3000 mm
- 10 x 410 x 3000 mm
- 10 x 623 x 3000 mm
- 12 x 410 x 3000 mm
- 12 x 623 x 3000 mm
- 12 x 310 x 3000 mm

**10 x 1250 x 3000 mm and 12 x 1250 x 3000 mm standard sizes are cut with the least wastage at the workshop.





The steps in the principles of application are followed to create the sub construction.



The first panel is prepared for the screw locations.



The aligned bottom panels are fixed with screws.



When driving the screws in, special attention should be paid for making sure the screws are 2,5 cm in from the top and bottom edges.



Fluting strips are placed in the desired size on the bottom surface of the panel fixed with screws.



The panels at the top are fixed onto the fluting strips with screws.



The screws should be driven into the panels in a way that connects the fluting strips and the profile.



Before overlapping on the fluting strips, a measurement should be taken to determine where the panel surface will come.



Once the measurements are taken, the panel screw locations are determined.



Balancing strips are placed on the middle sections of the area where the next panel will come.



The strips are fixed on the M profiles so that the panel screw spots do not coincide.



After fixing the laths, the next panel is brought over the strips and fixed in.



The screws need to be 2.5 cm in from the top and bottom edge.

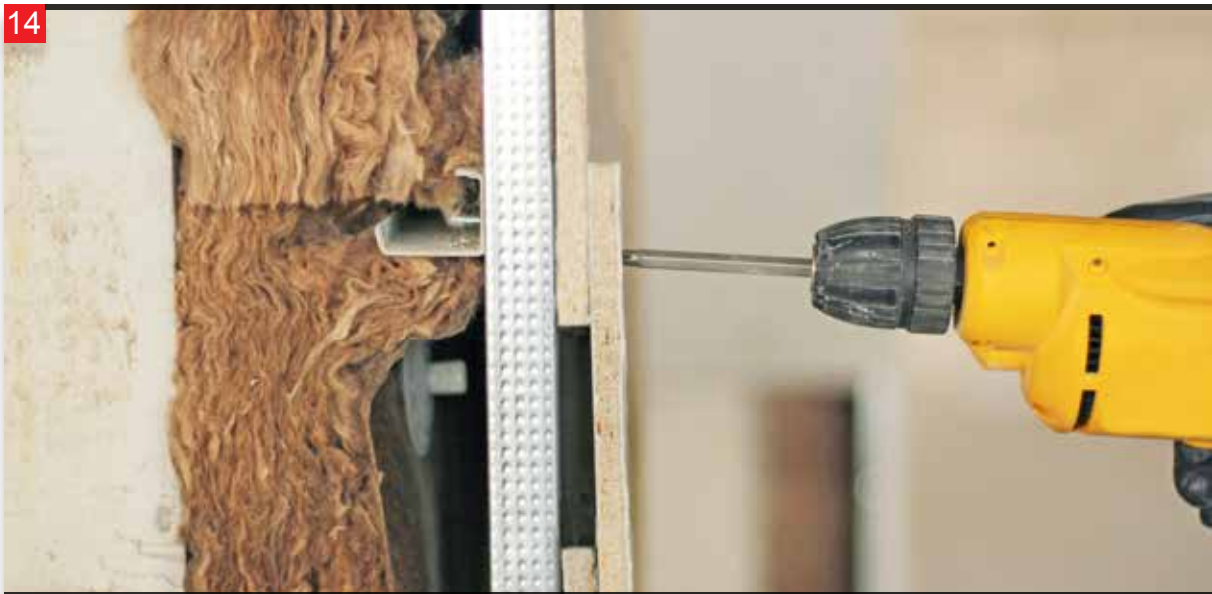

Carbon coated anti rust drywall screws should be used and driven in vertically.



CLASSIC OVERLAPPED APPLICATION

Preferred in applications for clapboard appearance. Mostly applied to wood patterned or patternless products.

In this application type, narrow strips are used. The application is started from the bottom. The subsequent strips are applied overlapping the strip below by 2,5 cm. Since the strips are screwed in at the top, the upper strip hides the screw heads in the lower strip. No paste is applied to the screw heads. Since the strips are screwed in at an angle, the corner turns are completed with accessories.

Standard Measurements:

- 10 x 175 x 3000 mm
- 10 x 205 x 3000 mm
- 12 x 175 x 3000 mm
- 12 x 205 x 3000 mm

**10 x 1250 x 3000 mm and 12 x 1250 x 3000 mm standard sizes are cut with the least wastage at the workshop.





The curve of the application surface is determined and suitable L consoles to which the L profiles are to be connected are attached.



The necessary amount of stone wool is applied to the wall surface on the fixed L consoles.



After fixing the stone wool on the wall surface, the L profiles are attached to the L console with triphone bolts.



4 After the L profiles are fixed to the L consoles the M profiles, to which the panels are to be fixed, are attached to the L profiles.



5 The panels are screwed onto the surface for which the bottom construction has been completed with rust proof screws.



6 2,5 cm is measured out from the top for the panel to be overlapped above.



Screws are driven into the measured points as a guide to the overlap panel.



The subsequent overlapping panels are aligned and screwed on the M profile surface.



Carbon coated anti rust drywall screws should be used and driven in vertically.



Measurements are taken for the subsequent panels.



2,5 cm distance from the top is left for the overlapping surface.



Screws are driven into the measured points as a guide to the overlapping panels.



The screws are applied for each M profile and steps 5 through 14 are repeated for all the panels.



PIPING APPLICATION

The piping application is a type of grooved application. Groove details are opened on the long sides of 3 meter strips cut from the whole plates. This is done in the factory setting just like the sizing. When these strips are applied in rows during assembly, a piping detail is created at the joints. This detail will prevent water from getting in.

Standard Measurements:

- 16 x 175 x 3000 mm
- 16 x 205 x 3000 mm

** 16 x 1250 x 3000 mm and 12 x 1250 x 3000 mm standard sizes are cut with the least wastage at the workshop.





The curve of the application surface is determined and suitable L consoles to which the L profiles are to be connected are attached.



The necessary amount of stone wool is applied to the wall surface on the fixed L consoles.



After fixing the stone wool on the wall surface, the L profiles are attached to the L console with triphone bolts.



After the L profiles are fixed to the L consoles the M profiles, to which the panels are to be fixed, are attached to the L profiles.



The panels are screwed onto the surface, for which the bottom construction has been completed, with anti rust screws.







The aligned panels are screwed onto the M profile with anti rust screws.



Carbon coated anti rust drywall screws should be used and driven in vertically.



The screws are applied for each M profile and steps 5 through 14 are repeated for all the panels.



DIMENSIONAL APPLICATION

The panels produced in standard dimensions, then cut with the least wastage, with holes drilled at the factory and beveled edges, are mounted directly on the wall surfaces with dowels. When necessary, insulation materials are placed under the plus group product modules.

Standard Measurements:

- 12 x 171 x 346 mm
- 12 x 346 x 521 mm
- 12 x 171 x 696 mm
- 12 x 596 x 1250 mm

** 12 x 1250 x 3000 mm and 12 x 1250 x 3000 mm standard sizes are cut with the least wastage at the workshop.



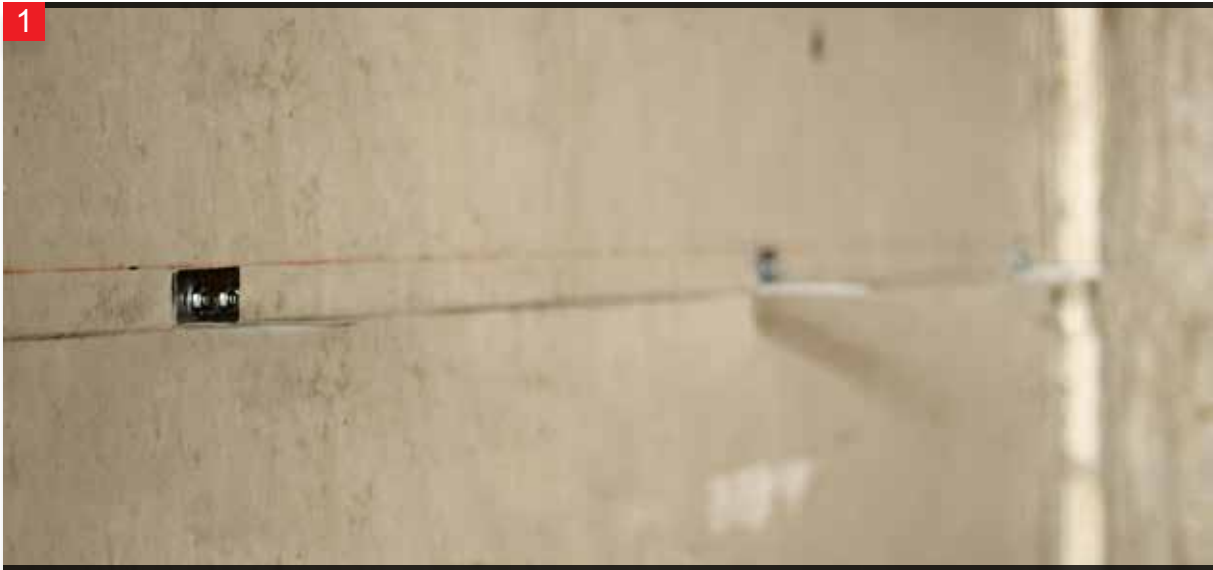

1
The curve of the application surface is determined and suitable L consoles to which the L profiles are to be connected are attached.



2
The necessary amount of stone wool is applied to the wall surface on the fixed L consoles.



3
After fixing the stone wool on the wall surface the L profiles are attached to the L console with triphone bolts.



After the L profiles are fixed to the L consoles the M profiles, to which the panels are to be fixed, are attached to the L profiles.



Anti rust screws are used on the L profiles of M profiles.

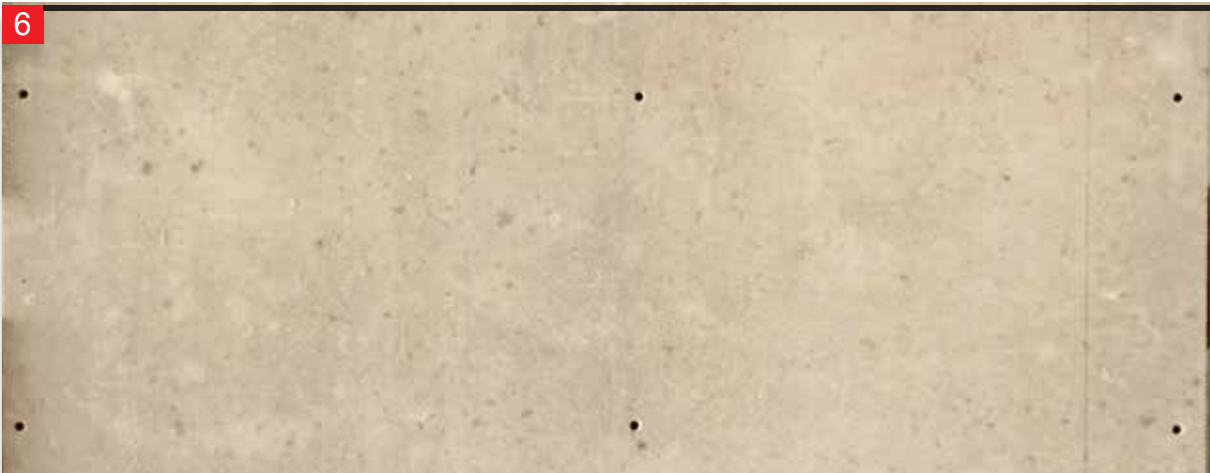

On dimensional applications the panels are applied to a plain base.



Dimensional coating systems are mostly applied with taşonit®, generally with monolin®, fugalin® and frapan®.



When necessary the insulation material is mounted under the plus group product modules.



5 mm of working space is left between panels and assembly is continued.

10



Carbon coated anti rust drywall screws should be used and driven in vertically.

11





The screws are applied for each M profile and steps 6 through 12 are repeated for all the panels.

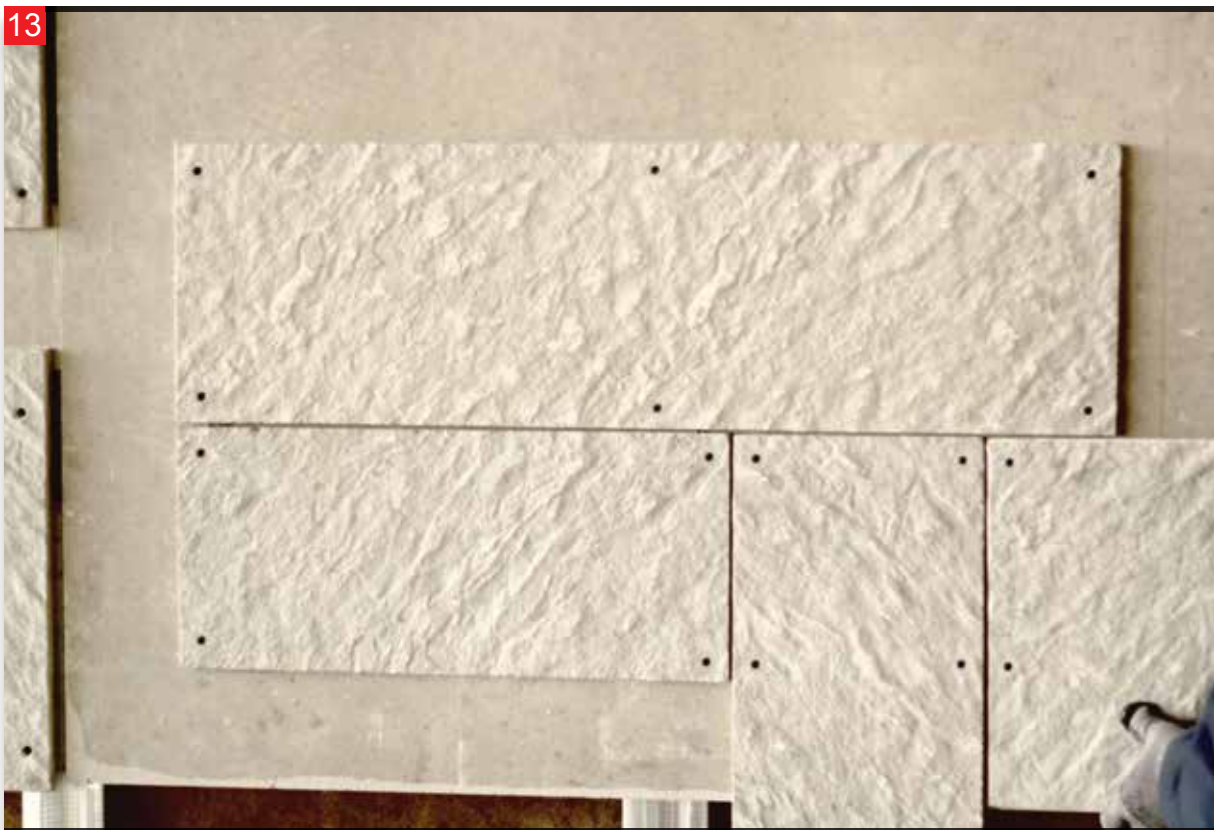

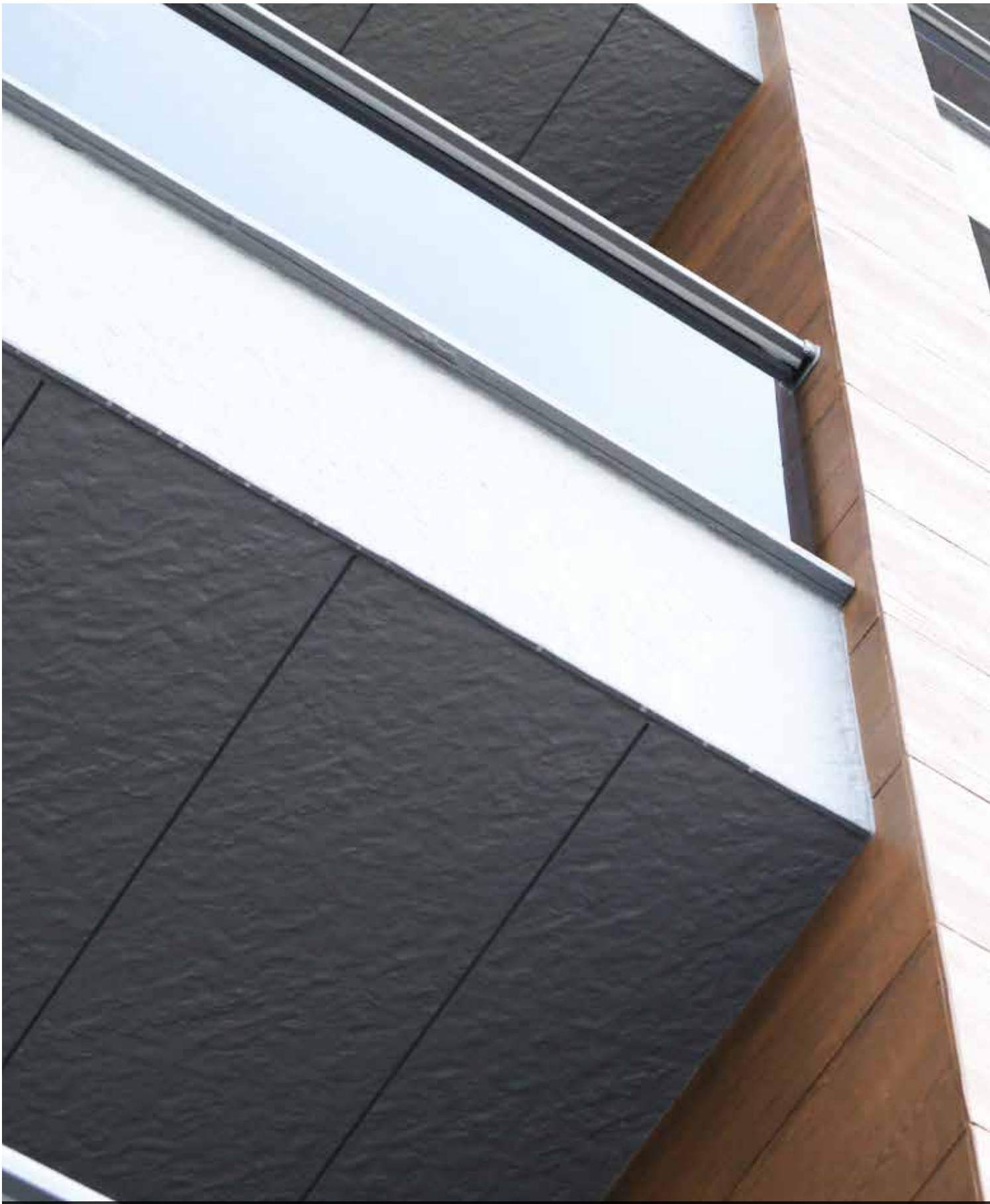

APPLICATION
EXAMPLES FROM
THE PROJECTS













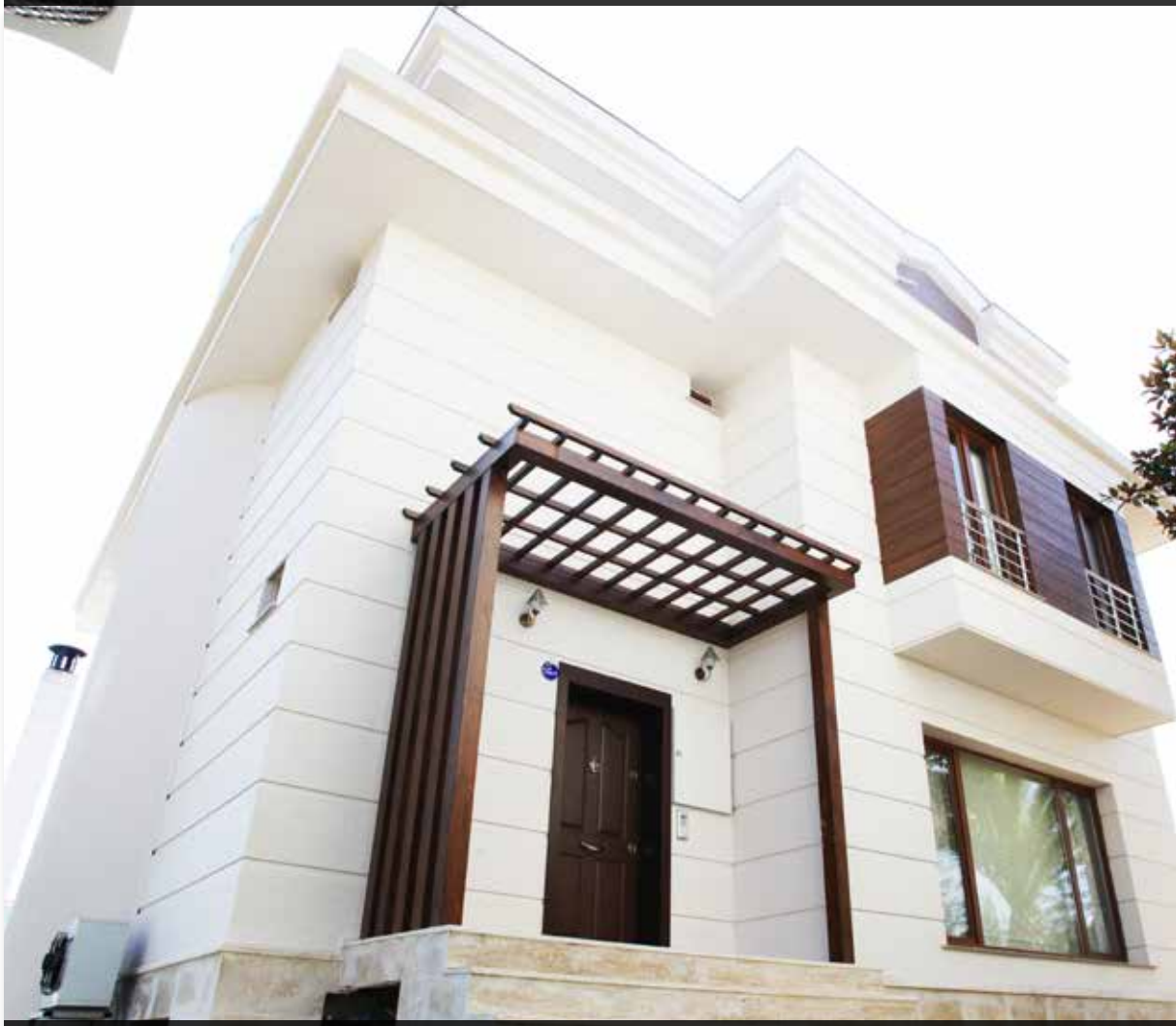













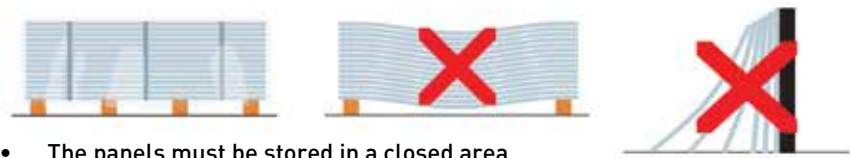

 <h1>TRANSPORTING PRINCIPLES</h1>	
 SHIPPING	 <ul style="list-style-type: none"> • Our panels are transported domestically and internationally with the plate edges painted and the Tepe Betopan® emblem. • The panels are on wood pallets covered in plastic with rings and corner brackets added. • During transport, the panels must be covered in canvas.
 CARRYING	 <ul style="list-style-type: none"> • When the panels are being carried one by one they are recommended to be carried vertically or as close as possible to vertical so as not to be bent.
 STORAGE	 <ul style="list-style-type: none"> • The panels must be stored in a closed area. • Whether in storage or at the assembly site, the panels must be left in lateral position and should not be leaned either laterally or vertically on a wall or similar surfaces. • If the panel packages are to be stacked, caution should be taken to align them. • If the panels are not going to be used for a long period the packages should be completely covered in plastic to avoid being affected from heat and humidity changes (stay stable). • After panels are taken out from the package for using, the package should be covered over again with the plastic.

✓ The storage area must be closed.

✓ Do not take the plastic cover off until use.

✓ When stacking pallets the pallet, feet should be lined up one on top of the other.

✓ Do not take off the steel strips until use.

✓ The materials should be placed on the smoothest ground possible.



When storing the pallets, a maximum of 5 pallets should be placed on top of each other neatly.



When loading, only two pallets at a time should be loaded.



When loading make sure that the pallets are placed on the truck in a balanced way.



Pallets ready for transport.

BİLKENT HOLDİNG

Bilkent Holding Companies were founded by Prof. Dr. İhsan Doğramacı. Dilek Construction, the first company, was founded in 1968, then Tepe Furniture, the group's first industrial company, was opened for service in 1969. Today, there are over 40 companies operating under Bilkent Holding roof together with affiliations. The companies are active in construction, industry, science and information technology, investment and the service sectors, and Bilkent Holding is owned Bilkent University.





An evolution has begun. Being led by Tepe Betopan...

TEPE BETOPAN YAPI MALZEMELERİ SAN. VE TİC. A.Ş.

HQ – BETOPAN FACTORY

Beytepe Köyü Yolu No: 5 Bilkent 06800 Ankara / Türkiye
betopan@betopan.com.tr

TEPEPAN FACTORY

Alcı Mh. ASO 2. ve 3. Organize Sanayi Bölgesi 2026. Cadde No:12 Sincan / Ankara
t. +90 312 266 45 51 **pbx f.** +90 312 266 01 50

www.betopan.com.tr / www.tepepan.com.tr [✉ betopan@betopan.com.tr](mailto:betopan@betopan.com.tr) [🐦 twitter.com/tepebetopan](https://twitter.com/tepebetopan) [f www.facebook.com/tepebetopan](https://www.facebook.com/tepebetopan)

Tepe Betopan is a company of
BİLKENT HOLDİNG.